

GE
Measurement & Control

Pressure Automated Calibration Equipment

User manual - K0443 Revision B

PACE5000



PACE6000



© 2008 General Electric Company. All Rights Reserved. Specifications are subject to change without notice. GE is a registered trademark of General Electric Company. Other company or product names mentioned in this document may be trademarks or registered trademarks of their respective companies, which are not affiliated with GE.

Introduction

This manual contains Installation and operating instructions for PACE Pneumatic Pressure Controllers.

Safety

The manufacturer has designed this equipment to be safe when operated using the procedures detailed in this manual. Do not use this equipment for any other purpose than that stated, the protection provided by the equipment may be impaired.

This publication contains operating and safety instructions that must be followed to make sure of safe operation and to maintain the equipment in a safe condition. The safety instructions are either warnings or cautions issued to protect the user and the equipment from injury or damage.

Use qualified * technicians and good engineering practice for all procedures in this publication.

Pressure

Do not apply pressures greater than the maximum working pressure to the equipment.

Toxic Materials

There are no known toxic materials used in construction of this equipment.

Maintenance

The equipment must be maintained using the procedures in this publication. Further manufacturer's procedures should be carried out by authorized service agents or the manufacturer's service departments.

Technical Advice

For technical advice contact the manufacturer.

* A qualified technician must have the necessary technical knowledge, documentation, special test equipment and tools to carry out the required work on this equipment.

General Specification

Display	LCD: Colour display with touch screen
EMC	EN 61326
Electrical safety	EN 61010-1, UL 61010-1, CSA 22.2, No. 61010-1 and IEC 61010-1
Power Supply	PACE 5000: Input range: 100-240V (50/60Hz) 2A, Installation Category II, Fuse T2AH250V
	PACE 6000: Input range: 100-120/200-240V (50/60Hz) 5A, Installation Category II, Fuse T5AH250V
Pressure safety	Pressure equipment Directive - class: sound engineering practice (SEP)

Introduction

Environmental Conditions

Operating Environment	Indoor use only
Operating temperature	10°C to 50°C (50° to 122°F)
Storage temperature	-20°C to 70°C (-4° to 158°F)
Ingress protection	IP20 (EN 60529)
Operating humidity	5% to 95% RH (non-condensing)
Vibration	MIL-PRF-28800 Type 2 class 5 Style E/F
Operating altitude	Maximum 2000 metres (6560ft)
Pollution degree	2

Abbreviations

The following abbreviations are used in this manual; the abbreviations are the same in the singular and plural.

a	Absolute	min	Minute or minimum
a.c	Alternating current	mm	millimetre
ALT	Altitude	mV	millivolts
ASCII	American Standard Code for Information Interchange	MWP	Maximum working pressure
BSP	British pipe thread	No	Number
CAS	Calibrated airspeed	NPT	National Pipe Thread
CSK	Countersunk	PACE	Pressure automated calibration equipment
d.c.	Direct current	Para.	Paragraph
DPI	Digital Pressure Instrument	PDCR	Pressure transducer
etc.	And so on	PED	Pressure equipment directive
e.g.	For example	psi	Pounds per square inch
Fig.	Figure	PTX	Pressure transmitter
ft	Foot	ROC	Rate of climb (vertical speed)
g	Gauge	RS232	Serial communications standard
GPIB	General purpose interface bus	Rt CAS	Rate of Calibrated airspeed
Hg	Mercury	Rt MACH	Rate of MACH
Hz	Hertz	Rx	Receive data
IAS	Indicated airspeed	SCPI	Standard commands for programmable instruments
IDOS	Intelligent digital output sensor (GE product)	SDS	Sales data sheet
i.e.	That is	SELV	Separated (or Safety) extra low voltage
IEEE 488	Institute of Electrical and Electronic Engineers standard 488 (for programmable devices with a digital interface)	Tx	Transmit data
in	Inch	UUT	Unit under test
kg	kilogram	V	Volts
kts	knots	+ve	Positive
m	Metre	-ve	Negative
mA	milliampere	°C	Degrees Celsius
max	Maximum	°F	Degrees Fahrenheit
mbar	Millibar		

Related Publications

K0447 PACE 5000/6000 User Guide and Safety Instructions

K0450 PACE Series Calibration Manual

K0476 Pressure Control Module User Guide and Safety Instructions

K0472 Remote Communications Manual

K0469 Heritage Communications Manual - Instrument Emulation

Symbols



This equipment meets the requirements of all relevant European safety directives. The equipment carries the CE mark.



This symbol, on the equipment, indicates that the user should read the user manual.



This symbol, on the equipment, indicates a warning and that the user should refer to the user manual.

Ce symbole, sur l'instrument, indique que l'utilisateur doit consulter le manuel d'utilisation. Ce symbole, dans le manuel, indique une situation dangereuse.

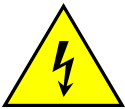

This symbol warns the user of the danger of electric shock.

Ce symbole alerte l'utilisateur sur le danger de choc électrique.



Do not dispose of this product as household waste. Use an approved organisation that collects and/or recycles waste electrical and electronic equipment. For more information, contact one of these:

- Our customer service department: www.gemeasurement.com
- Your local government office.



WARNINGS

TURN OFF THE SOURCE PRESSURE(S) AND CAREFULLY VENT THE PRESSURE LINES BEFORE DISCONNECTING OR CONNECTING THE PRESSURE LINES. PROCEED WITH CARE.

ONLY USE EQUIPMENT WITH THE CORRECT PRESSURE RATING.

BEFORE APPLYING PRESSURE, EXAMINE ALL FITTINGS AND EQUIPMENT FOR DAMAGE. REPLACE ALL DAMAGED FITTINGS AND EQUIPMENT. DO NOT USE ANY DAMAGED FITTINGS AND EQUIPMENT.

DO NOT EXCEED THE MAXIMUM WORKING PRESSURE OF THE INSTRUMENT.

THIS EQUIPMENT IS NOT RATED FOR OXYGEN USE.

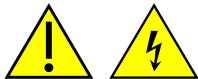

THE GROUND LEAD OF THE INSTRUMENT MUST BE CONNECTED TO THE AC SUPPLY PROTECTIVE SAFETY GROUND.

ISOLATE THE POWER SUPPLY BEFORE MAKING ANY ELECTRICAL CONNECTIONS TO THE REAR PANEL.

Pressure Units and Conversion Factors

Pressure units	Factor (hPa)	Pressure units	Factor (hPa)
mbar	1.0	cmH ₂ O @ 20°C	0.978903642
bar	1000.0	mH ₂ O @ 20°C	97.8903642
Pa (N/m ²)	0.01	kg/m ²	0.0980665
hPa	1.0	kg/cm ²	980.665
kPa	10.0	torr	1.333223684
MPa	10000.0	atm	1013.25
mmHg @ 0°C	1.333223874	psi	68.94757293
cmHg @ 0°C	13.33223874	lb/ft ²	0.4788025898
mHg @ 0°C	1333.223874	inH ₂ O @ 4°C	2.4908891
inHg @ 0°C	33.86388640341	inH ₂ O @ 20°C	2.486413
mmH ₂ O @ 4°C	0.0980665	inH ₂ O @ 60°F	2.487641558
cmH ₂ O @ 4°C	0.980665	ftH ₂ O @ 4°C	29.8906692
mH ₂ O @ 4°C	98.0665	ftH ₂ O @ 20°C	29.836983
mmH ₂ O @ 20°C	0.097890364	ftH ₂ O @ 60°F	29.8516987

Unit Conversion

Convert FROM pressure VALUE 1 in pressure UNITS 1 TO pressure VALUE 2 in pressure UNITS 2, calculate as follows:

$$\text{VALUE 2} = \text{VALUE 1} \times \frac{\text{FACTOR 1}}{\text{FACTOR 2}}$$

Intentionally Blank

Table of Contents

1 Description 1-1

1.1 Introduction 1-1

2 Installation 2-1

2.1 Packaging 2-1

 Packaging List 2-1

2.2 Packaging for Storage or Transportation 2-1

2.3 Preparation for Use 2-1

2.4 Pneumatic Connections 2-2

 Pressure supply (Ref: Figure 2-1) 2-3

 Installation 2-4

 Supply Equipment 2-5

 Pneumatic Connection Examples (Ref: Figure 2-3), (Ref: Figure 2-4) & (Ref: Figure 2-5) 2-5

2.5 Rack-mount Option (Ref: Figure 2-6) 2-8

 General 2-8

 Procedure 2-9

2.6 Electrical connections 2-9

 Connecting (Ref: Figure 2-7) 2-9

 Pressure Control Module Input and Output Connectors 2-10

 Communication Connections (Ref: Figure 2-8) 2-11

 RS232 Interface 2-12

 IEEE 488 Interface 2-13

3 Operation 3-1

3.1 Preparation 3-1

3.2 Power-up Sequence 3-2

3.3 Measure Mode 3-3

 AUTO-RANGE (only available with two-channel instruments) 3-5

Introduction

	Controller Off – Increasing Set-point	3-5
	Controller Off – Decreasing Set-point.....	3-5
	Controller On – Increasing Set-point.....	3-5
	Controller On – Decreasing Set-point.....	3-5
3.4	Control Mode.....	3-6
	Controlling to a new Set-point.....	3-7
	Effort Meter	3-8
	Controlling to Ambient/Zero Pressure.....	3-8
3.5	Operation and Example Procedures.....	3-10
	Introduction	3-10
	Measure and Control Modes.....	3-10
	Task.....	3-11
	Divider.....	3-12
	Preset	3-14
3.6	Global Set-up Selections.....	3-15
	Status Area Settings.....	3-16
3.7	Barometric Reference Option.....	3-16
3.8	Supervisor Set-up.....	3-17
3.9	Instrument Status	3-18
	Software	3-19
4	Maintenance	4-1
4.1	Introduction	4-1
4.2	Visual Inspection.....	4-1
4.3	Cleaning.....	4-1
4.4	Test.....	4-1
4.5	Calibration	4-2
4.6	Replacement Parts	4-2
	Fuse Replacement (Ref: Figure 4-1).....	4-2
	Filter Replacement (Ref: Figure 4-2).....	4-4

	Pressure Module Replacement (Ref: Figure 4-3).....	4-5
5	Testing and Fault Finding	5-1
5.1	Introduction	5-1
5.2	Standard Serviceability Test.....	5-1
5.3	Fault Finding.....	5-3
5.4	Approved Service Agents	5-4
6	Reference and Specification.....	6-1
6.1	Installation Notes	6-1
	Gas Supply.....	6-1
	Supply Conditioning Equipment.....	6-1
	Maximum Working Pressure.....	6-1
	Supply Contamination	6-1
	Systems without a Negative Supply.....	6-2
	The need for a Negative Supply (for Optimum Performance).....	6-2
6.2	Operational Requirements.....	6-4
	Negative or Vacuum Supply	6-4
	Oil Contamination	6-4
	Pump Performance	6-4
	Venting	6-5
	Output Port.....	6-5
	Reference Port.....	6-5
6.3	Icons.....	6-6
6.4	Measure Set-up.....	6-9
	Pressure Zero	6-9
	Process.....	6-9
	Task.....	6-9
	Units.....	6-9
	Global set-up.....	6-9
	Set-up Zero.....	6-9

Introduction

6.5	Control Set-up.....	6-10
	Vent.....	6-10
	Nudge	6-10
	Set-point Limits	6-10
	Slew Rate.....	6-10
	Control Mode.....	6-10
	Global Set-up.....	6-11
	Status.....	6-11
	Vent Set-up	6-11
6.6	Global Set-up.....	6-11
	Supervisor Set-up.....	6-11
	Calibration	6-11
	Save/Recall User Set-up	6-11
	Display	6-11
6.7	Supervisor Set-up.....	6-12
	Protective Vent	6-12
	In Limits.....	6-12
	Alarms.....	6-12
	Comms	6-12
	Timeout.....	6-20
	Idle Timeout	6-21
	Gas Head Correction	6-21
	Power Up.....	6-21
	Lock Tasks	6-21
	Change PIN	6-21
	User Defined Units.....	6-21
	Instrument Alias Name.....	6-21
	Language.....	6-22
	Adding a Language.....	6-22

	Restore as Shipped Settings	6-23
6.8	Options.....	6-24
	Option Enable Process.....	6-24
	Options in the Task Menu.....	6-24
	Leak Test Option	6-25
	Switch Test Option.....	6-26
	Test Program Option	6-28
	Barometric Reference Option.....	6-34
	Aeronautical Option.....	6-35
	Analogue Output Option.....	6-41
	Volts-free Contact Option	6-42
6.9	Calibration	6-43
6.10	Communications - Instrument Emulation.....	6-43
6.11	Specification	6-43
6.12	Return Goods/Material Procedure	6-43
	Safety Precautions.....	6-43
	Important Notice	6-44
6.13	Packaging Procedure	6-44
	Environment	6-44
6.14	Vacuum System Parts.....	6-45

Intentionally Blank

1 Description

1.1 Introduction

The PACE5000 single-channel and PACE6000 single/dual-channel, Pressure Automated Calibration Equipment measures and controls pneumatic pressures and displays, on a touch-screen, the pressure measurement and controller status. The touch-screen enables selections and settings in both measure and control modes. The instrument can be operated remotely through communication interfaces.



Figure 1-1 PACE5000 General view



Figure 1-2 PACE6000 General view

The rear of the instrument houses all the electrical and pneumatic output and input connections. The electrical connections provide an a.c. power supply, serial and parallel communication interfaces, d.c. output and logic input and output. The system pneumatic controller module contains a positive and negative pressure supply port, an output port, vent port and reference port.

The instrument can be mounted in a standard 19 inch rack system (rack-mount option).



Figure 1-3 PACE5000 Rear view

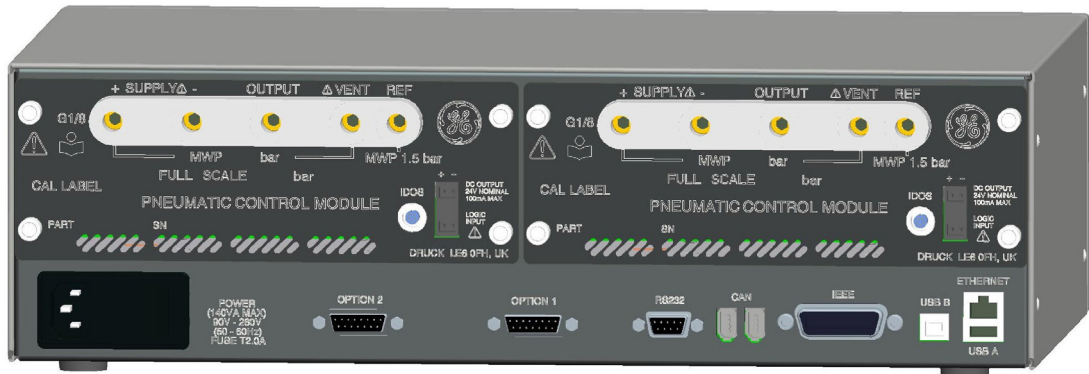

Figure 1-4 PACE6000 Rear view

Options available are detailed in the product datasheet.

Information and notes on applications ([Ref: Section 6, Reference and Specification](#)) or www.gemeasurement.com

2 Installation

2.1 Packaging

Check the contents of the PACE5000/6000 packaging with the list that follows:

Packaging List

1. PACE5000 or PACE6000 Pressure Controller.
2. Cable, power supply.
3. User guide and CD (UD-0001) containing the full documentation suite.
4. Pneumatic Control Module blanking plate (keep this plate for future use).



CAUTIONS

AFTER REMOVING A CONTROL MODULE, USE A BLANKING PLATE TO KEEP THE FLOW OF COOLING AIR.

AFTER UNPACKING AN INSTRUMENT THAT HAS BEEN IN COLD CONDITIONS ALLOW TIME TO STABILISE AND ANY CONDENSATION TO EVAPORATE.

2.2 Packaging for Storage or Transportation

To store or return the instrument for calibration/repair do the procedures that follow:

1. Pack the instrument ([Ref: Section 6.13, Packaging Procedure](#)).
2. Return the instrument for calibration/repair complete the return goods procedure ([Ref: Section 6.12, Return Goods/Material Procedure](#)).

Note: The procedure above applies to the pressure control module as a separate item.

2.3 Preparation for Use

The instrument can be used as a:

- Free-standing instrument positioned on a horizontal surface.
- Rack-mounted in a standard 19 inch rack using the rack-mount option kit ([Ref: Section 2.5, Rack-mount Option \(Ref: Figure 2-6\)](#)).

For free-standing instruments, the feet on the front of the base can be used elevate the instrument to a better viewing angle.

Note: Do not obstruct the air cooling outlet on the underside of the instrument and allow a free flow of air around the instrument, especially at high ambient temperatures.

Installation

2.4 Pneumatic Connections



WARNINGS

TURN OFF THE SOURCE PRESSURE(S) AND CAREFULLY VENT THE PRESSURE LINES BEFORE DISCONNECTING OR CONNECTING THE PRESSURE LINES. PROCEED WITH CARE.

ONLY USE EQUIPMENT WITH THE CORRECT PRESSURE RATING.

BEFORE APPLYING PRESSURE, EXAMINE ALL FITTINGS AND EQUIPMENT FOR DAMAGE. REPLACE ALL DAMAGED FITTINGS AND EQUIPMENT. DO NOT USE ANY DAMAGED FITTINGS AND EQUIPMENT.

DO NOT EXCEED THE MAXIMUM WORKING PRESSURE OF THE INSTRUMENT.

THIS EQUIPMENT IS NOT RATED FOR OXYGEN USE.

PARALLEL THREADS MUST BE USED. FEMALE THREAD TYPE IS PARALLEL THREAD TO ISO228/1 (DIN ISO228/1, JIS B0202) G1/8.

TAPERED THREADS NOT ALLOWED.

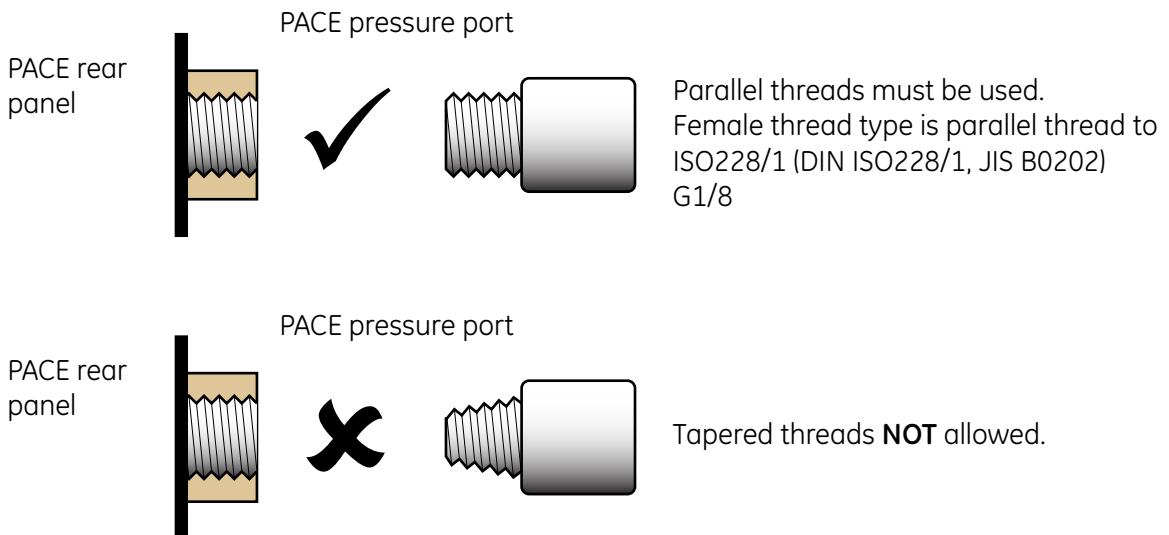

Connection		Port
Input	supply +	ISO228/1 G 1/8 parallel threads (DIN ISO228/1, JIS B0202)
	supply -	
Output	Output	ISO228/1 G 1/8 parallel threads (DIN ISO228/1, JIS B0202)
	Vent	
	Reference	

Refer to the data sheet for a complete range of adaptors.

Pressure supply (Ref: Figure 2-1)

1. The pressure supply must be clean, dry gas, nitrogen or air and at the correct pressure, (Ref: Section 6, Reference and Specification).
2. Make sure the user systems can be isolated and vented.
3. Connect pressure and vacuum supplies to the SUPPLY + and SUPPLY - connection ports.
4. Connect the Unit Under Test (UUT) to the required output connection port.

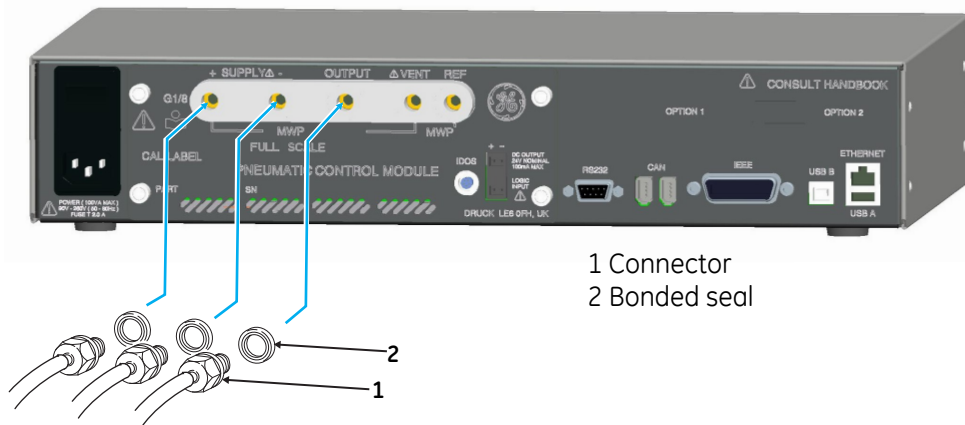

Figure 2-1 Pneumatic Connections

Note: For systems requiring NPT connections, please order optional NPT adaptors.

Installation

Installation

The safety of any system incorporating the equipment is the responsibility of the assembler of the system.

The instrument requires a positive pressure supply, instruments operating in an absolute range or negative pressure range require a vacuum supply.

A vacuum supply should be used for a fast response for instruments operating near atmospheric pressure.

For dual channel operation two independent pressure and vacuum supplies can be used.

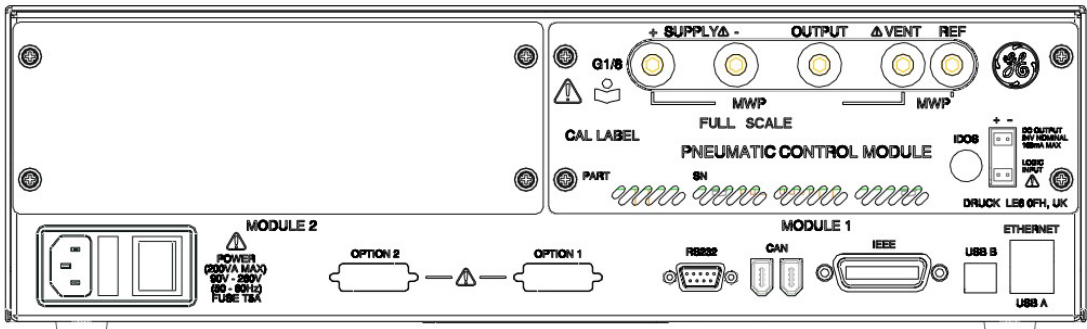

Figure 2-2 Pressure module rear view

Note: When using two pressure modules (Ref: Section , Pressure Module Replacement (Ref: Figure 4-3)) make sure that:

- The module with the highest pressure rating is fitted to the right hand side Module 1 position as viewed from the rear of the product refer to (Ref: Figure 2-2).
- If two modules have the same pressure rating, make sure that the module with the higher serial number is fitted to the right hand side Module 1 position as viewed from the rear of the product.

Note: All pneumatic connections must comply with the Pressure Equipment Directive (PED) or other regional pressure standards.

Note: When connecting the output ports of two pressure modules together make sure both are either:

- below 70 bar

OR

- between 100 to 210 bar.

To prevent over-pressurisation of pneumatic parts and maintain compliance with the PED do not mix categories.

Supply Equipment

Pneumatic supplies should have isolation valves and, where necessary, conditioning equipment.

The positive pressure supply should be regulated to between 110% of the full-scale pressure range and MWP stated on the control module.

To protect the instrument from over-pressure a suitable protection device (such as a relief valve or bursting disc) must be fitted to prevent over pressurization.

On instruments without a negative supply, the positive pressure discharges from the system to atmosphere through the negative supply port. Pipe the negative port to a safe discharge area or fit a diffuser to the negative port.

During system pressure vent operations, the pressure discharges from the system to atmosphere through the negative and vent ports. Pipe both ports to a safe discharge area or fit a diffuser to the negative port.

Pneumatic Connection Examples (Ref: Figure 2-3), (Ref: Figure 2-4) & (Ref: Figure 2-5)

The examples that follow show a single channel connection detail, using supply equipment described above.

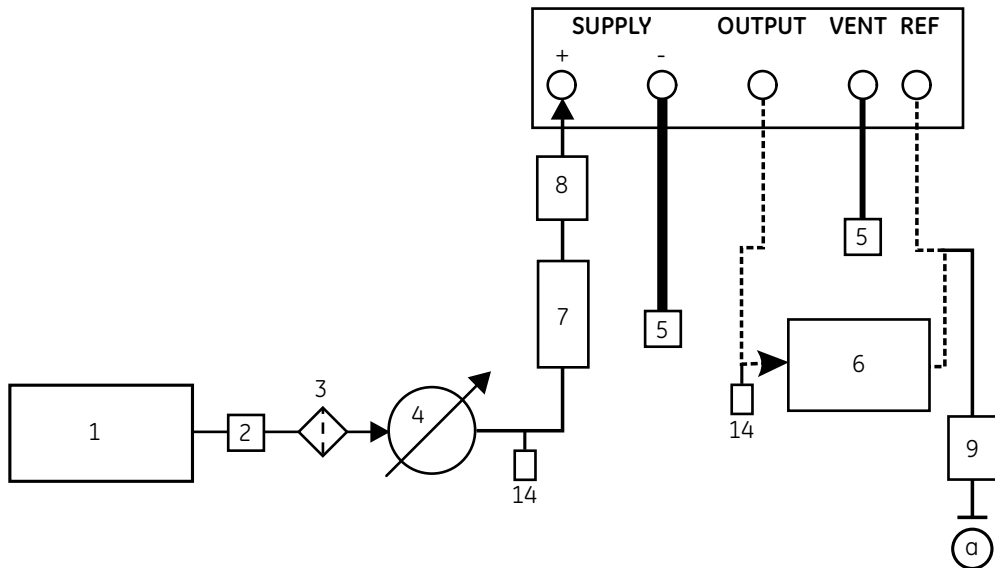

Figure 2-3 Pneumatic Connections without vacuum supply

- | | | |
|--|---------------------------------|---------------------------------------|
| 1) Pressure source | 2) Conditioner | 3) Filter |
| 4) Regulate to between 110% full-scale and MWP | 5) Diffuser* | 6) Unit under test |
| 7) Optional reservoir † | 8) Protection device ☉ | 9) Optional differential connection ★ |
| a) Atmosphere | 14) Manual external vent valves | |

Installation

Note: (Ref: Section 6, Reference and Specification) for details of other system components.

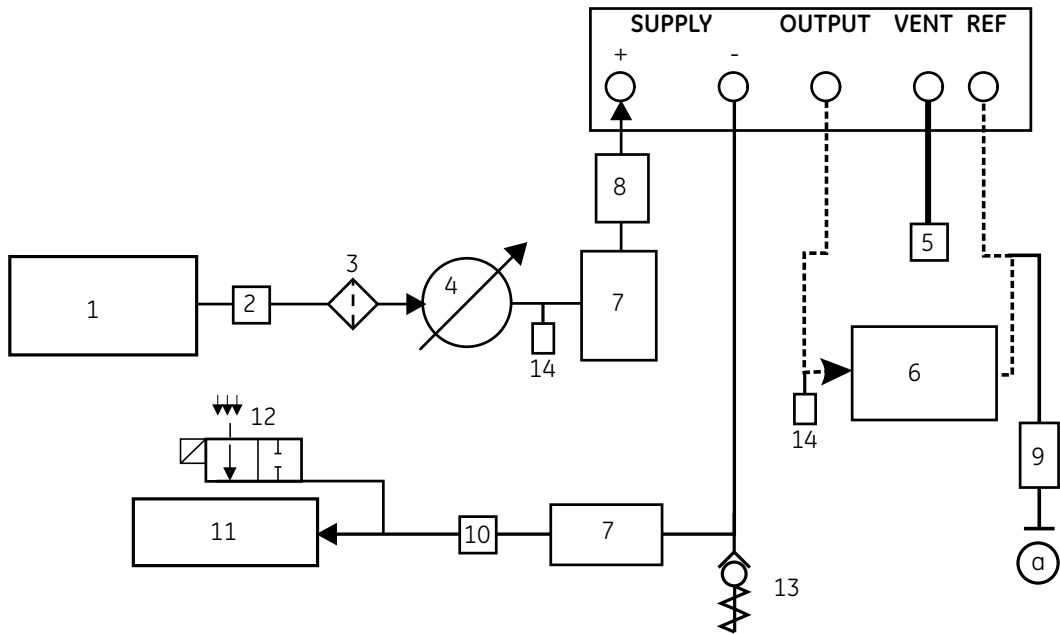

Figure 2-4 Pneumatic Connections with vacuum supply

- | | | |
|--|---------------------------------|--|
| 1) Pressure source | 2) Conditioner | 3) Filter |
| 4) Regulate to between 110% full-scale and MWP | 5) Diffuser* | 6) Unit under test |
| 7) Optional reservoir † | 8) Protection device ⊙ | 9) Optional differential connection ★ |
| 10) Oil mist trap | 11) Vacuum source | 12) Normally open electrical release valve |
| 13) Check valve ** | 14) Manual external vent valves | a) Atmosphere |

Note: The PACE option IO-VAC-SYS Vacuum System Check Valve Kit should be used in the vacuum line mounted near the PACE CM -ve port to exhaust most HP gas directly to atmosphere. The vacuum buffer volume needs to be rated at least to the highest system pressure.

Note: (Ref: Section 6, Reference and Specification) for details of other system components.

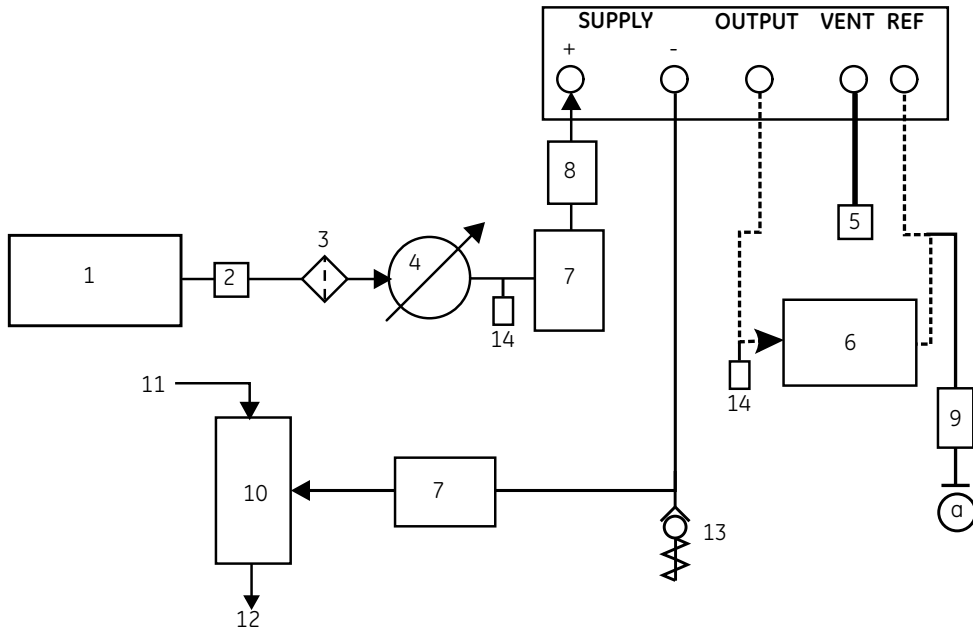

Figure 2-5 Pneumatic Connections with negative gauge pressure generator

- | | | |
|--|---|---------------------------------------|
| 1) Pressure source | 2) Conditioner | 3) Filter |
| 4) Regulate to between 110% full-scale and MWP | 5) Diffuser * | 6) Unit under test |
| 7) Optional reservoir † | 8) Protection device ⊙ | 9) Optional differential connection ★ |
| 10) Vacuum generator ‡ | 11) Source pressure (regulated compressed air supply) | 12) Exhaust to atmosphere |
| 13) Check valve ** | 14) Manual external vent valves | a) Atmosphere |

Note: (Ref: Section 6, Reference and Specification) for details of other system components.

* High pressure gas exhaust - depending on pressure range.

** Optional vacuum system kit, allows the -ve port gas to be directly discharged to atmosphere, by-passing the vacuum pump.

† Optimum controller transient response and minimum time to set-point may be degraded if either the pneumatic supply or vacuum system has restricted flow. Installing a reservoir volume, which has larger capacity than the load volume, located in close proximity to the controller supply ports can improve the controller response.

‡ Optional negative gauge pressure generator kit.

⊙ To protect the control module, for ranges of 70 bar and above from over-pressure a suitable protection device (such as a relief valve or bursting disc) must be fitted to limit the applied supply pressure to below the MWP.

★ Optional differential connection kit.

Installation

2.5 Rack-mount Option (Ref: Figure 2-6)

General

There must be enough space at the rear of the instrument for all the cables and pipes. The length of the cables and pipes must allow for the removal and fitment of the instrument. The cooling air of the instrument must not be obstructed. Allow a free flow of air through the equipment rack and around the instrument, especially at high ambient temperatures.

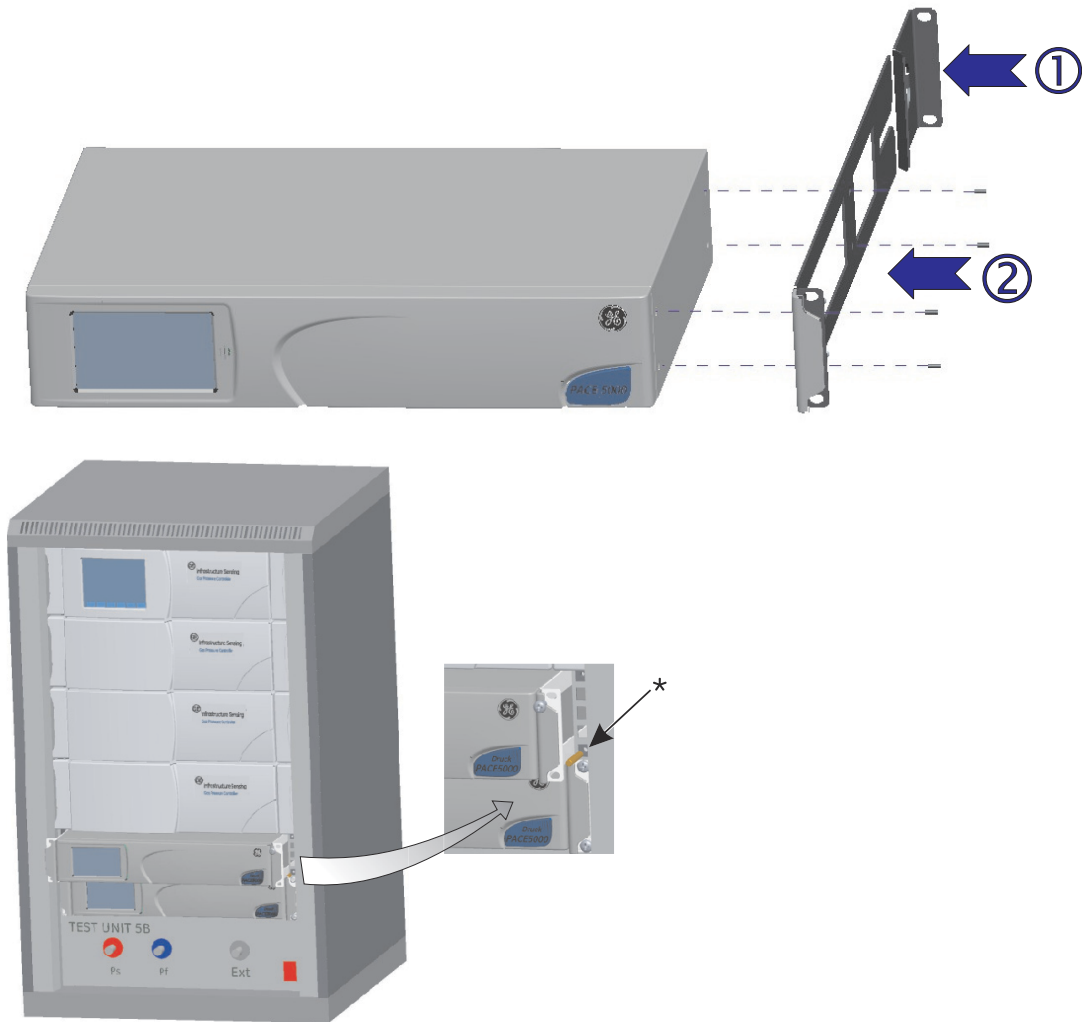
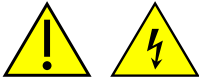

Figure 2-6 Rack-mounting

Procedure

1. Locate bracket in rack assembly ①.
2. Remove the four M3x10mm countersunk screws from each of the instrument side panels.
3. Locate the two brackets ② on each side of the instrument.
4. Secure with the four countersunk screws.
5. Support the instrument and connect the cables and pipes.
6. Refer to the electrical connections below before fitting the instrument into the rack.
7. Temporarily locate the two spigots* to each side of the equipment rack.
8. Locate and slide the instrument into the rack.
9. Locate the instrument on the spigots*.
10. Secure the instrument in the equipment rack with two of the screws and washers (supplied).
11. Remove the two spigots* and replace with the remaining two screws and washers (supplied).

2.6 Electrical connections



WARNINGS

THE GROUND LEAD OF THE INSTRUMENT MUST BE CONNECTED TO THE AC SUPPLY PROTECTIVE SAFETY GROUND.

ISOLATE THE POWER SUPPLY BEFORE MAKING ANY ELECTRICAL CONNECTIONS TO THE REAR PANEL.

Connecting (Ref: Figure 2-7)

1. Install an accessible power isolator to use as the disconnecting device in the power supply circuit.
2. For the power input power supply range, Installation Category and VA (Ref: [General Specification](#)).

Note: The power must be supplied by a fused or overload-protected power supply.

3. Connect the power supply to the instrument.
4. Switch the power supply on.
5. Check that the front panel display shows the power-up sequence (Ref: [Section 3.2, Power-up Sequence](#)).

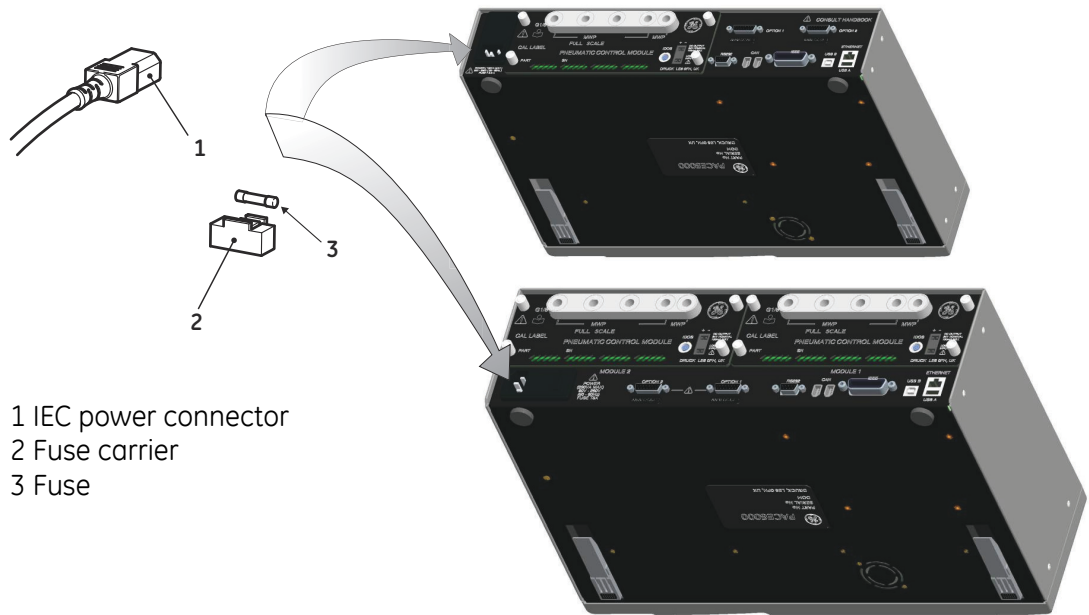

Figure 2-7 Electrical Connections

Pressure Control Module Input and Output Connectors

24V DC Output @ 100mA maximum

4-way connector: pin "+" = +24 Vdc
pin "-" = 0 Vdc

An integral self-resetting fuse protects this output.

Logic (switch) Input

4-way connector: Input
Output

This facility can be used to trigger the instrument from a pressure switch contact during the Pressure Switch Task ([Ref: Section 3.4, Control Mode](#)).

Connections are not polarised and can be connected either way. Integral opto-isolators protect this input circuit.

This facility can be energised by external SELV compliant equipment.

Communication Connections (Ref: Figure 2-8)

Connect the applicable connectors into the rear panel communications ports and, if appropriate, secure with the captive screws.

Note: Refer to the data sheet for a list of optional communication ports.

Refer to the data sheet for a list of standard shipped communication ports.

Set the required parameters in Supervisor Setup/communications menu, (Ref: Section 3.8, Supervisor Set-up).

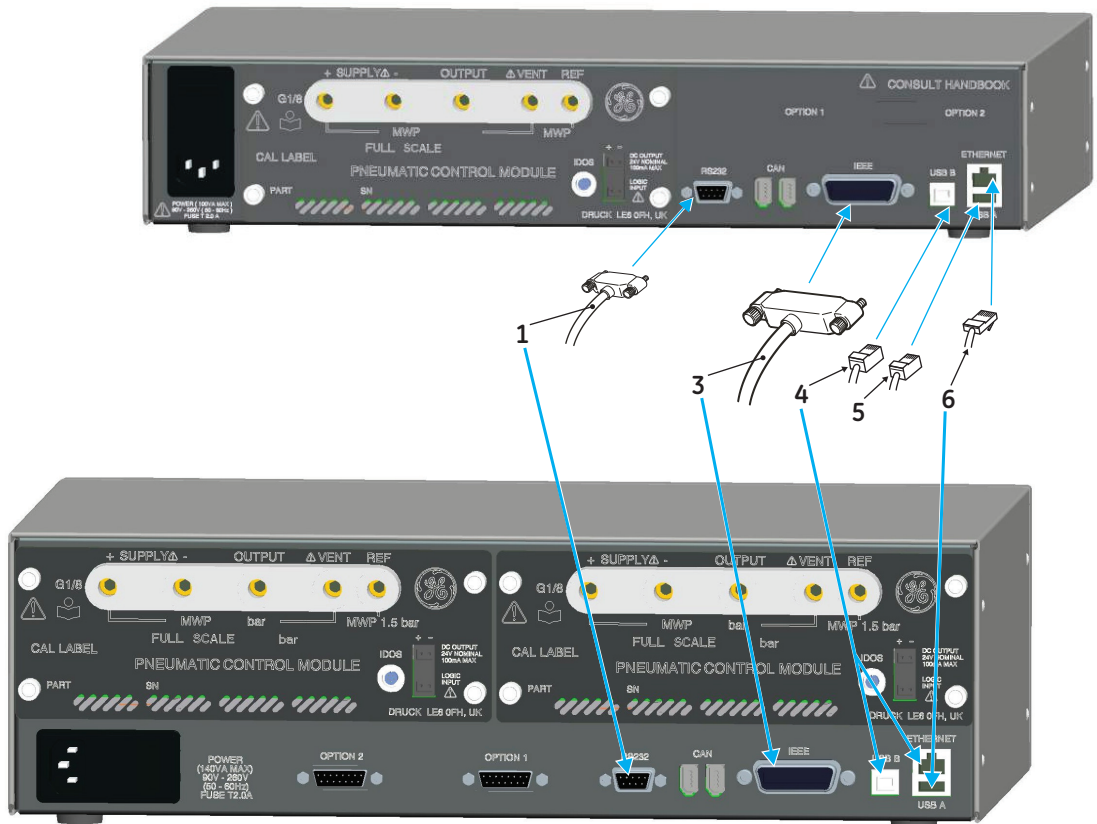

Figure 2-8 Communication Connectors

- 1 RS232
- 5 USB A

- 3 IEEE488
- 6 Ethernet

- 4 USB B

RS232 Interface

When using the RS232 interface, a cable must be connected directly from the instrument to a suitable port on the computer in a 'point to point' link. The pin connections for the 9-pin D-type, RS232 connector and the relationship between the instrument and the RS232 control signals, together with device interconnection interface is shown in (Ref: Table 2-1). The instrument is configured as Data Circuit Terminating Equipment (DCE).

Instrument		Control Line		Computer/Printer	
Instrument Function	Connector 9-way D-type Pin No.	Signal Direction	RS232 Terminology	Connector Type	
				9-way D-type Pin No.	25-way D-type Pin No.
RxD (I/P)	3	←	TxD	3	2
TxD (O/P)	2	→	RxD	2	3
GND	5	↔	GND	5	7
CTS (I/P)	7	←	RTS	7	4
RTS (O/P)	8	→	CTS	8	5
Pulled high internally	1	→	RLSD (DCD)	1	8
Not connected	4	←	DTR	4	20
Pulled high internally	6	↔	DSR DCE Ready	6	6
Equipment chassis	Connector shell	↔	Cable Screen	-	1

Table 2-1 RS232 Connections

Handshaking Connections

Software handshaking use: TXD, RXD and GND.

Hardware handshaking use: TXD, RXD, GND, CTS, RTS and DTR.

IEEE 488 Interface

The interface complies with IEEE 488 standard.

The IEEE 488 parallel interface connects a computer/controller to one or more PACE instruments and other instruments.

Up to 30 instruments can be connected through a high-speed data bus to the computer/controller.

Note: The length of each IEEE 488 cable must be less than 3 metres to comply with the EMC requirements (Ref: [Section 6, Reference and Specification](#)).

Single Unit Installation (Ref: [Figure 2-9](#))

1. Connect an IEEE 488 connector/cable assembly to the rear panel of the instrument.
2. Connect the other end of the connector/cable assembly to the IEEE 488 connector on the controller/computer.
3. Change the IEEE 488 communication parameters ([Ref: Section 6.7, Supervisor Set-up](#)).

Multiple Unit Installation (Ref: [Figure 2-9](#))

To install multiple units use stacking plugs to link the first instrument and second instrument as follows.

1. Connector to rear panel of first instrument ([Ref: Illustration](#)).
2. Connector from controller/computer ([Ref: Illustration](#)).
3. Connector to rear panel of second instrument ([Ref: Illustration](#)).
4. Connect the IEEE 488 connector on the controller/computer and the other connector into the next instrument.
5. Repeat this procedure for all the instruments in the system.
6. Use the Supervisor set-up (communications) menu on each instrument to set-up the required communication parameters ([Ref: Section 3.8, Supervisor Set-up](#)).

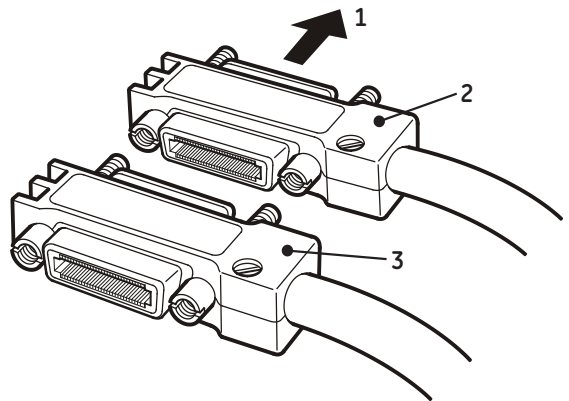

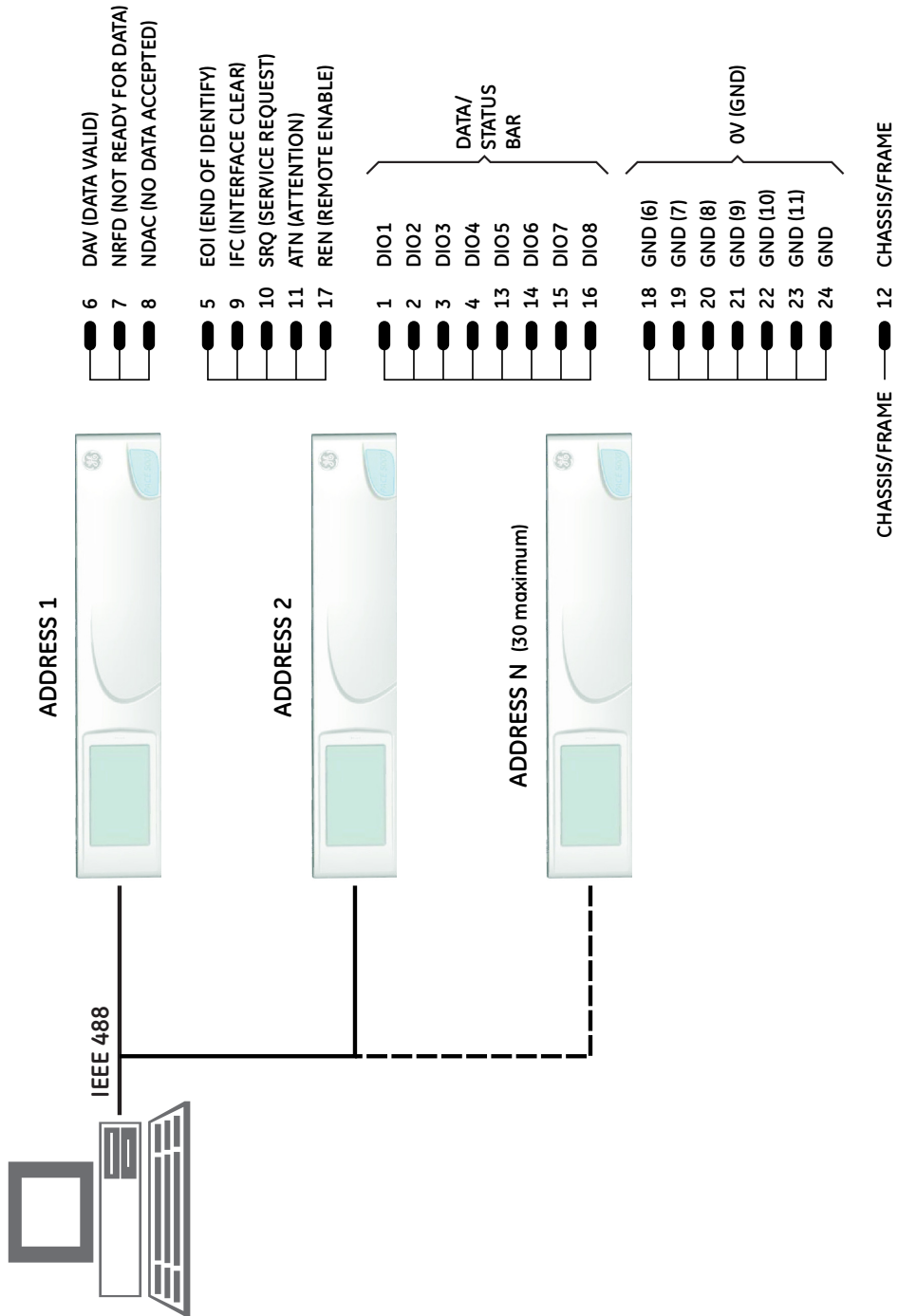

Figure 2-9 IEEE 488 Connection

3 Operation

This section contains quick reference charts detailing all the available functions and the set-up menu.

3.1 Preparation

Make sure the electrical cables and pneumatic pipes comply with the installation requirements ([Ref: Section 2, Installation](#)).

Before use do the following:

1. If necessary, do the maintenance task ([Ref: Section 4, Maintenance](#)).
2. For bench-top, single instrument operation do the following:
 - a. Connect the instrument to the electrical supply.
 - b. Inspect the pneumatic hoses for damage, ingress of dirt and moisture.
3. Before use, the instrument should be tested.
4. Review and become familiar with the procedure before starting a process on a component or system.

Note: The touch-screen can be permanently damaged by sharp objects.

Operation

3.2 Power-up Sequence

The following sequences of operation shows the instrument display.

Note: The following sequence is an example, the values and selections displayed depend on the range(s) and options enabled in the instrument (Ref: Figure 3-1).

1. Set the power supply to ON:
2. The display shows the power-up sequence.
3. The instrument carries out a self-test.
4. If the test finds a fault, the display shows an error (Ref: Section 5.3, Fault Finding).
5. If the self-test is successful the system enables the touch screen and changes to measure mode.
6. The touch screen shows the measured pressure in the parameters selected in set-up.
7. The instrument is now ready for use.

Note: The PACE 6000 shows a single display (default) this is the left hand pressure control module. Change to dual display in Global Set-up/Display.

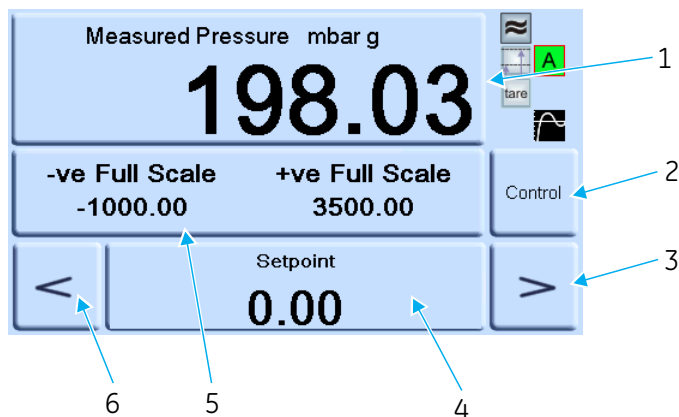
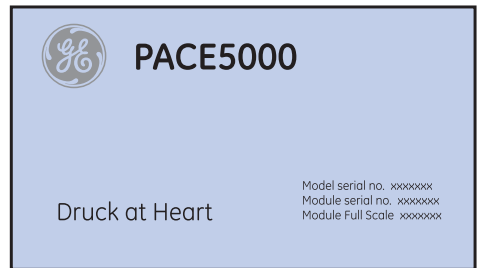
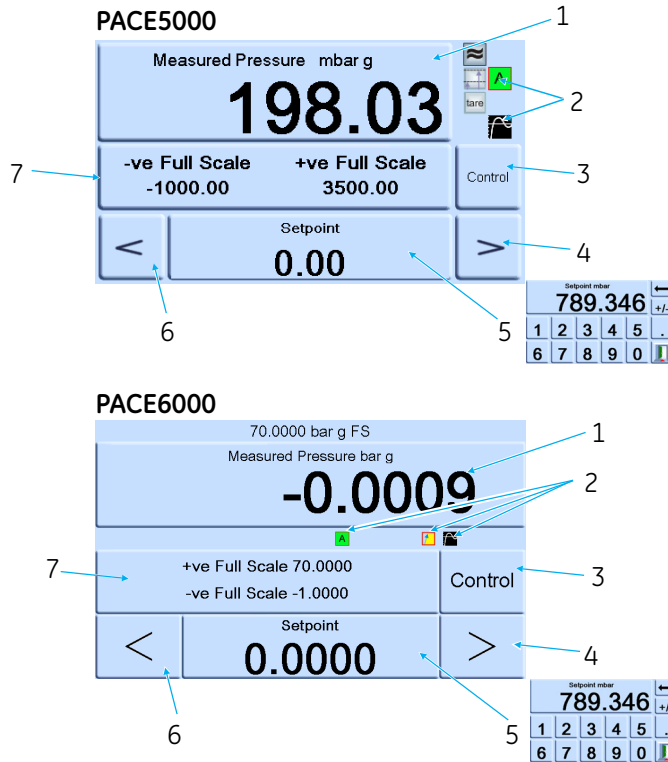

Figure 3-1 Touch screen areas

- | | | | | | | | |
|---|--|---|-----------------|---|----------|---|-----------------|
| 1 | Measure set-up | 2 | Control/Measure | 3 | Nudge up | 4 | Set-point entry |
| 5 | Status (touch to enter control set-up) | 6 | Nudge down | | | | |

3.3 Measure Mode



- 1 Pressure measurement of current selected sensor in current selected pressure measurement units
- 2 Current enabled functions
- 3 Control/measure selection
- 4 Nudge up, changed in control set-up
- 5 Current set-point value, change with numeric keys
- 6 Nudge down, changed in control set-up
- 7 Status area, changed in global set-up

Figure 3-2 Display Icons

	Auto zero		Control mode with over-shoot		Percentage
	Reference level difference (gas head correction)		Control mode with no over-shoot		Timed zero
	Control mode active		Filter pressure reading		Tare enabled
	Control mode passive		Linear rate		Zero
	Control mode gauge		Maximum rate		

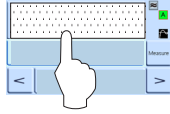
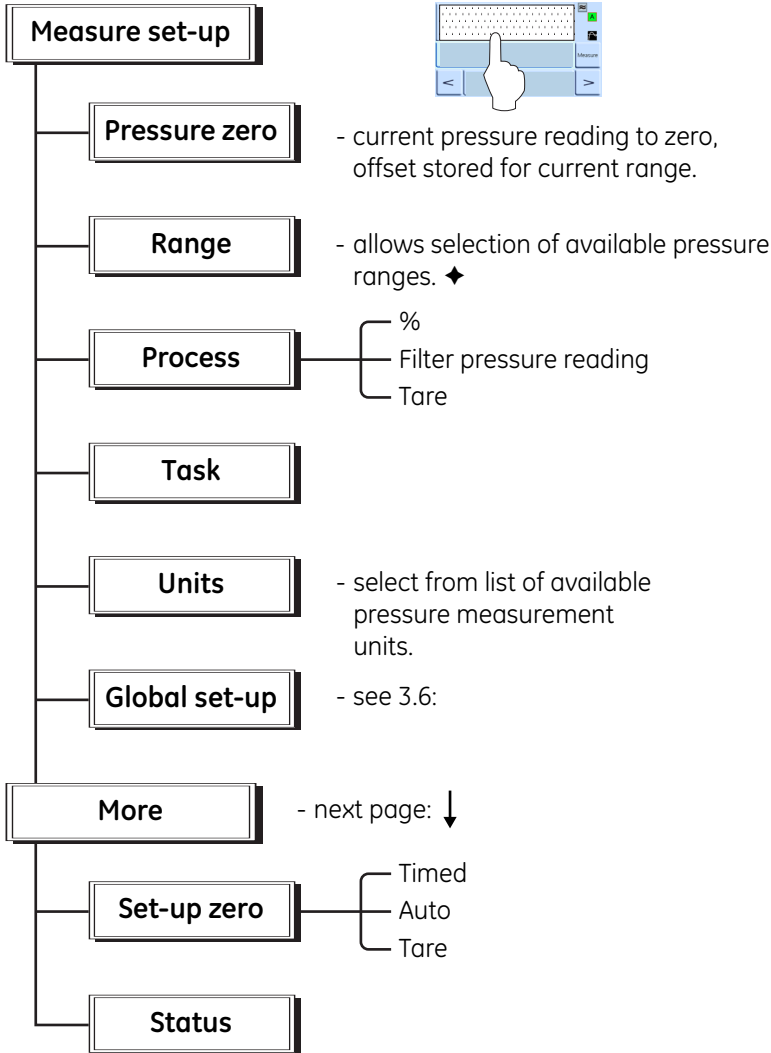

PACE5000

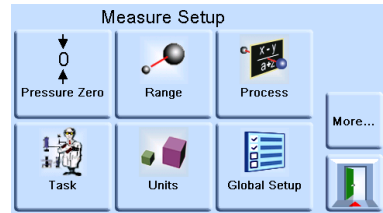

PACE6000

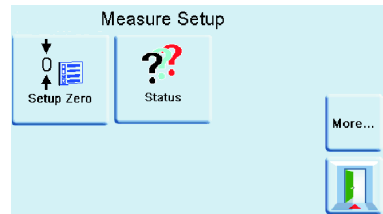
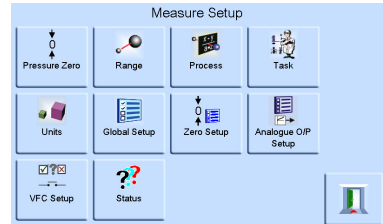

- ◆ Absolute range selection available when barometric option installed. Auto-range only available with two-channel instruments.



Exit set-up.



Next page of menu options. Loops from last page to first page.

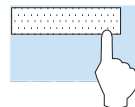

Stores settings and exits set-up.

AUTO-RANGE (only available with two-channel instruments)

Note: Not all Auto-Range and task functions are available using the remote communications, this allows more flexibility to the remote programmer.

Controller Off – Increasing Set-point

With both controllers in Measure mode, if a set-point within the range of the lower ranged controller is entered and Control is then selected the lower ranged controller controls to the entered set-point.

With both controllers in Measure mode, if a set-point above the range of the lower ranged controller is entered and Control is then selected, then the range is changed to the higher ranged controller and this then controls to the entered set-point.

Controller Off – Decreasing Set-point

With both controllers in Measure mode, if a set-point within the range of the higher ranged controller is entered and Control is then selected the higher ranged controller controls to the entered set-point.

With both controllers in Measure mode, if a set-point above the range of the lower ranged controller is entered and Control is then selected, then the higher ranged controller will control to this set-point. When the controller is in limits then the range is changed to the lower ranged controller and this then controls to the entered set-point.

Controller On – Increasing Set-point

With the lower ranged controller in Control mode, if a set-point within the range of the lower ranged controller is entered then the lower ranged controller controls to the entered set-point.

If the set-point is increased to above the lower range but still within the higher range then the lower range controller switches off and that the higher range controller switches on and controls to the entered set-point.

Controller On – Decreasing Set-point

With the higher ranged controller in Control mode, if a set-point within the range of the higher ranged controller is entered then the higher ranged controller controls to the entered set-point.

If the set-point is decreased to within the lower range then the higher range controller will control to this set-point. When the controller is in limits then the range is changed to the lower ranged controller and this then controls to the entered set-point.

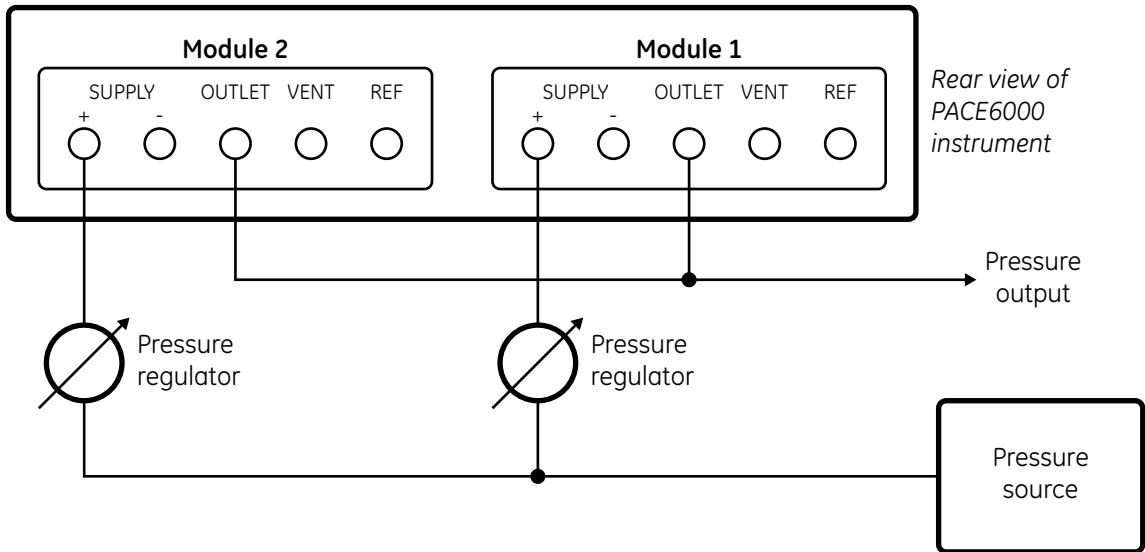

3.4 Control Mode

In measure mode, press **Control** and the instrument changes to control mode.

Press **Measure** and the instrument stops controlling pressure and changes to measure mode:

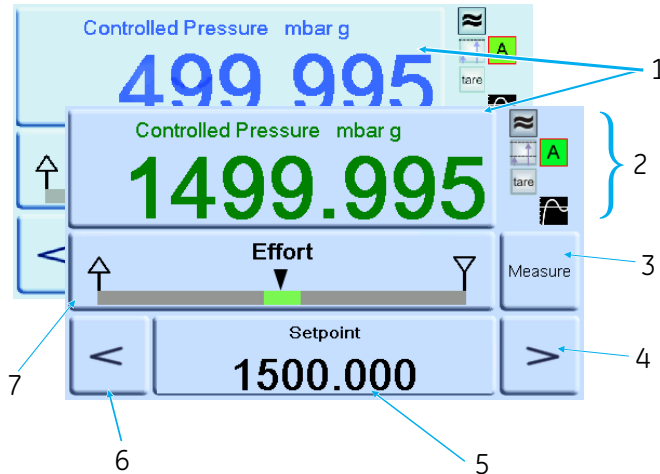



Key to display:

- 1 Current measured pressure value (in limits green, out of limits blue).
- 2 In active control mode.
 - Pressure reading filter ON.
 - Head (pressure) value applied.
 - Control mode with overshoot.
 - Tare enabled.

- 3 Press to switch between controlled pressure and measured pressure.
- 4 Nudge up.
- 5 Set-point, press and the display changes to numeric keys.
- 6 Nudge down.
- 7 Status area shows effort meter set in global set-up, press to enter control set-up.

Note:

	Active mode - control active, except in measure mode.
	Passive mode - when the controller achieves inlimits condition, measure mode is automatically selected.
	Gauge mode - when the controller achieves zero gauge inlimits condition, measure mode is automatically selected and the zero valve opens.

Controlling to a new Set-point

1. To change the set-point value, touch the set-point area of the screen and the display shows the numeric keys.
2. Set the new set-point value.

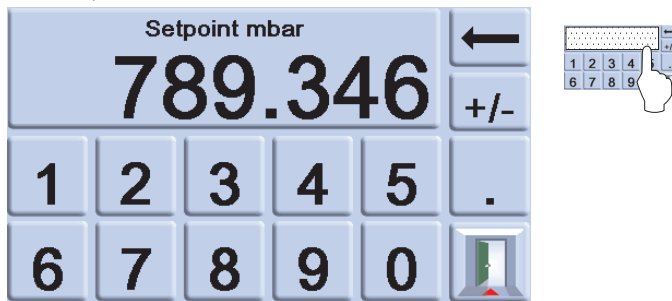

3. If necessary, use the ← key to remove the last digit in the set-point value display.
4. To save the new set-point, touch the set-point area of the screen. This returns the display to the measured pressure screen and showing the new set-point.
5. Touch the escape  to leave the numeric setting unchanged.
6. To control pressure to the new set-point value press the **Control** key.
7. The display shows the pressure value changing as the instrument controls to the new set-point, at the set rate of change.

Note: When changing from measured to controlled mode the displayed pressure digits change from black (measured pressure) to blue (controlled pressure out of limits) to green (controlled pressure in-limits).

8. If enabled, the effort meter shows the effort the controller exerts to achieve the set-point.
9. The status area can be changed to various displays showing pressure and controller

performance.



Effort Meter

Note: In normal controlled pressure conditions the effort meter stays within the band (green). If the status indicator moves outside the band there may be a leak into or out of the system.

Controlling to Ambient/Zero Pressure

1. Use the numeric key display and set the new set-point value to ambient or zero gauge pressure.
2. When the display shows the new set-point value, press the **Control** key.
3. The display shows the pressure value changing as the instrument controls to the new set-point, at the set rate of change.
4. When the display shows ambient or zero pressure, press the **Measure** key to switch off the controller and return to measure mode.

Control set-up

Vent

- Yes/No ♦

Nudge resolution

- Sets set-point nudge resolution.
- 1st to 7th digit.

Set-point limits

Upper
Lower
Enable/disable

Slew rate

Linear - Enter units/second
Maximum rate
Toggle between: fast/no overshoot

Control mode

Active - Continuous control to set-point
Passive - Controls outside user defined band
Gauge - Controls from zero gauge to set-point

Global set-up

- see 3.6:

Status

- see 3.9:

Vent set-up

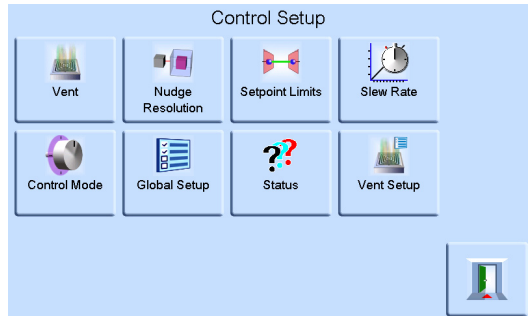
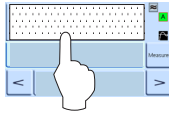

Exit set-up.

♦ Replaced by Go to Ground when in aeronautical option.

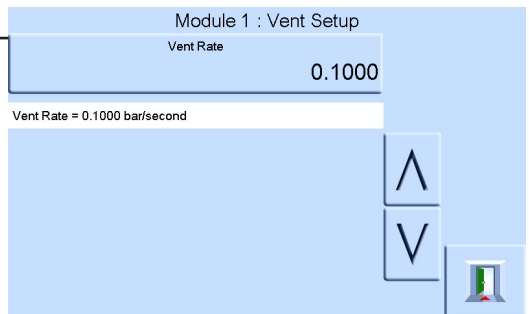

3.5 Operation and Example Procedures

Introduction

Before operation, the instrument must be connected to the correct electrical and pneumatic supplies (Ref: Section 2, Installation).

Switch the instrument ON, the display shows measured pressure mode (except when regulator mode is selected) and the task set before the power-off.

Measure and Control Modes

The instrument operates in the two modes that follow:

- Measure mode, the instrument works as a precision pressure indicator and shows the pressure measured at the output port.
- Control mode, the instrument works as a precision pressure controller and shows the controlled pressure measured at the output port. Pressing Task enables various pre-determined functions:

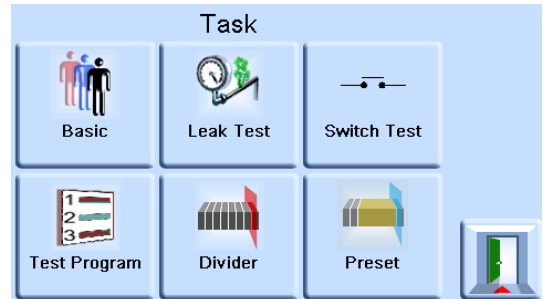
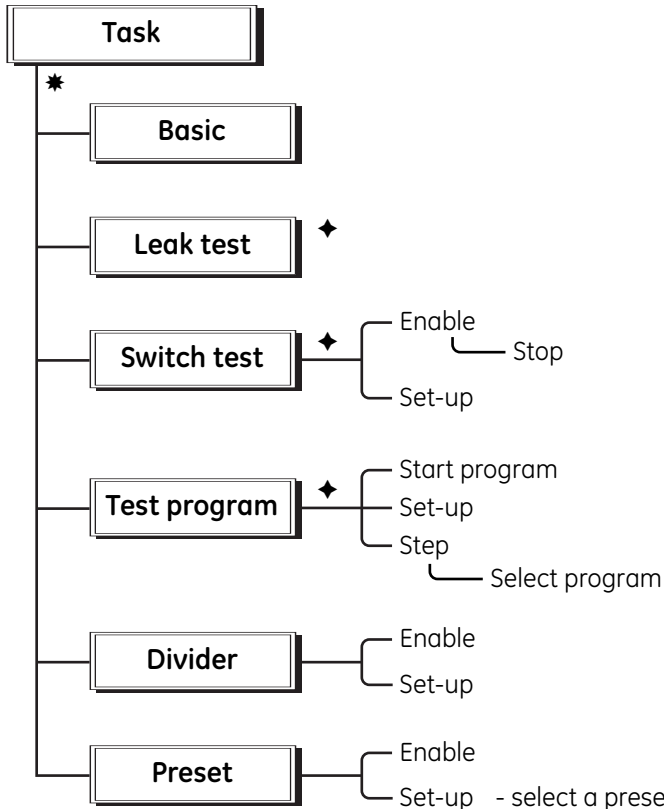

◆ Option refer to 6.8.

* Selecting a task exits the menu and changes the display to the task selected.

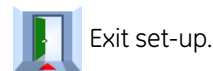

The display shows the task screen. When selected, e.g. Basic, the screen changes to show the selected task.

Task

To control pressure in the task do the following:

1. Select the required units of pressure measurement from the measure set-up menu.
2. Press the status area and enter control set-up.
3. Select the required slew rate.

Note: The display changes to show the type of slew rate selected.

4. Select the required vent slew rate in vent set-up.



CAUTION

USE THE VENT SET-UP TO PREVENT DAMAGE TO RATE-SENSITIVE EQUIPMENT CONNECTED TO THIS CONTROLLER. THE VENT SLEW RATE SETTING IS INDEPENDENT OF THE CONTROLLER SLEW RATE SETTINGS.

5. Return to the task screen. In basic task, use the numeric keys to enter a set-point.
6. Press the status area and enter control set-up, select the required slew rate.
7. Press the **Control** key to start controlling pressure.
8. The screen display changes as follows:
 - The current pressure reading changes from black to blue.
 - If enabled, the effort meter indicates the amount of work done (effort) by the controller.
9. When the controller achieves the selected pressure set-point, the screen display changes as follows:
 - The current pressure reading changes from blue to green.
 - If enabled, the effort meter shows the controller effort to keep the pressure at the set-point.
10. On completion of testing, select control set-up and select **Vent** to reduce the system pressure to near atmospheric pressure.

Note: This feature should be used to reduce system pressure to a safe value before disconnecting the Unit Under Test. The vent valve opens and remains open until a key press or receipt of a communications command. Always use the vent function before disconnecting pressure equipment from the output port.

11. Press the **Measure** key to return to measure mode. The screen display changes as follows:
 - The current pressure reading changes from blue/green to black.
 - If enabled, the effort meter indicates the controller at rest.

Divider

Select and set-up the divider task by pressing **Divider** from the task screen. The divider menu specifies high set-point, low set-point and then divides the span into a number of equal test points (min 2, max 25).

Divider menu structure

Select required units, Rate, etc. in the set-up menus. When Divider is then entered from the Task menu, these test point pressures and number of test points can be set.

By entering control mode, this allows the Divider sequence of test pressures (and controlled at the selected rate).

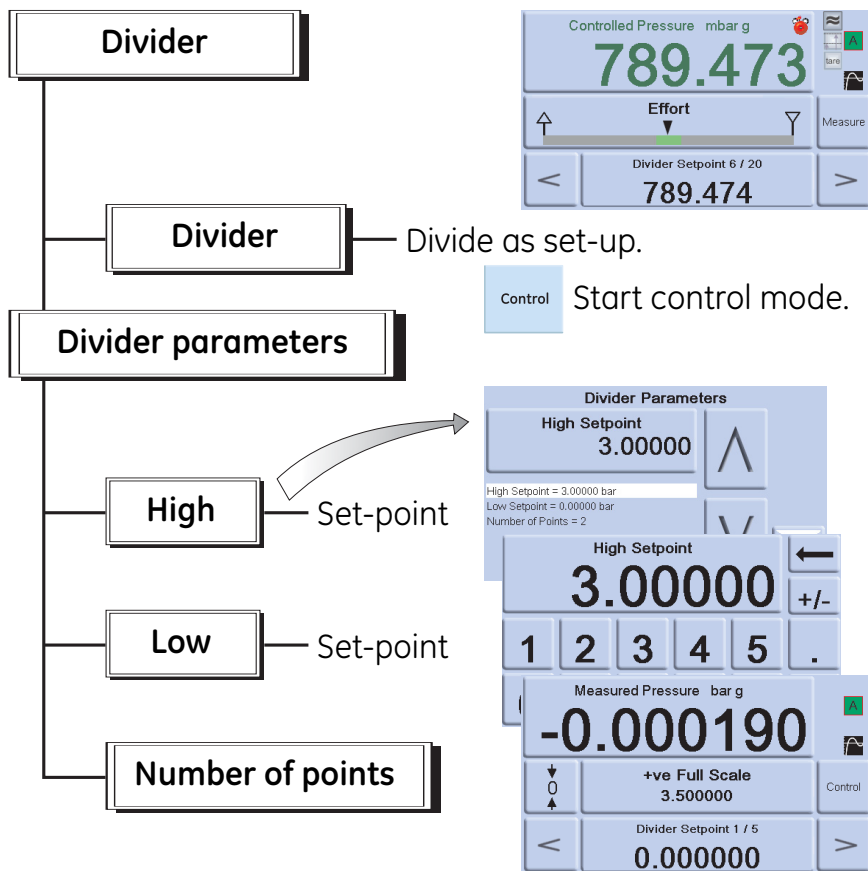

Example:

High set-point = 2 bar

Low set-point = 0 bar

Number of points = 5

Test pressures = 0, 0.5, 1, 1.5 and 2 bar

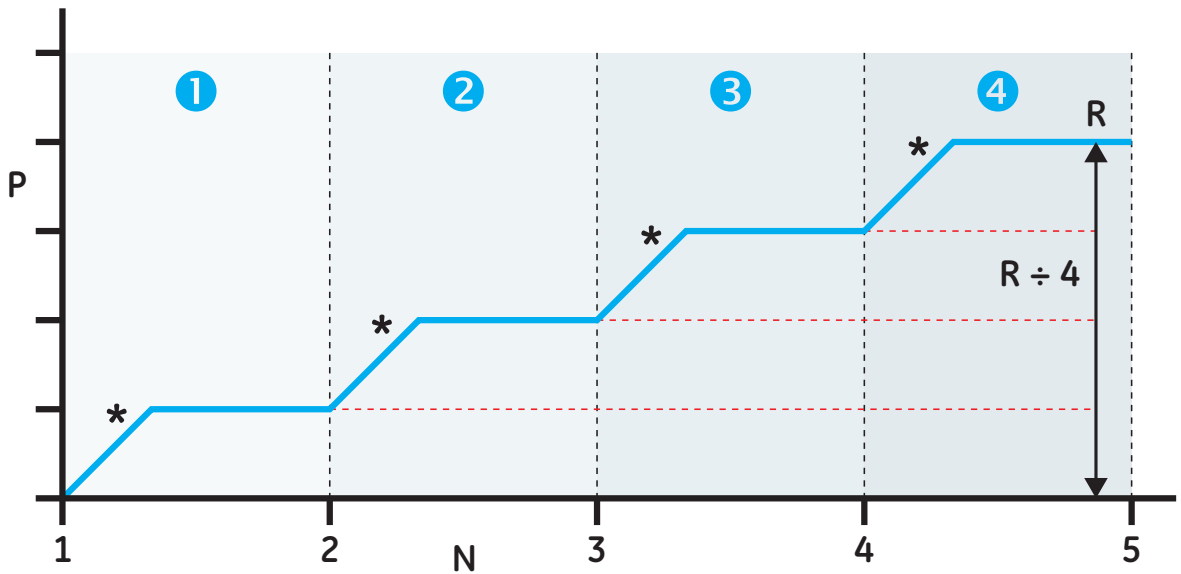

P = pressure N = Number of points R = range between low set-point (1) and high set-point (5)
 * controlled pressure to each set-point

Preset

The **Preset** function allows individual set-point values can be defined for each of 25 set-points.

The set-up function displays a preset number.

Pressing the soft key for that number assigns a pressure value to the key.

After setting all the 25 preset pressures, enter control mode.

Press a soft key to change to the pressure assigned to that key (and *controlled at the selected rate).

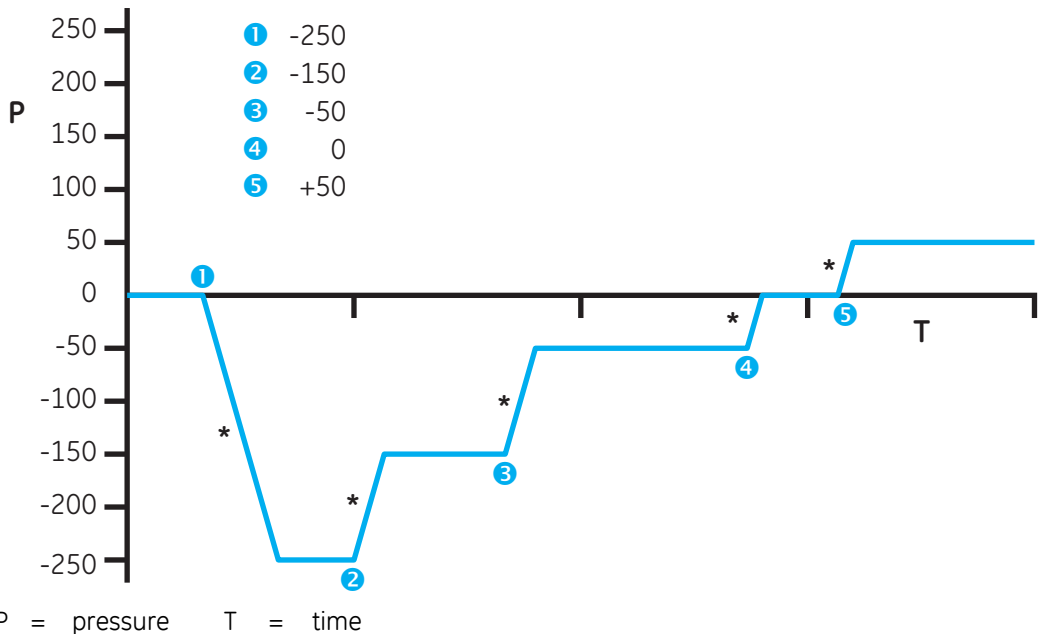
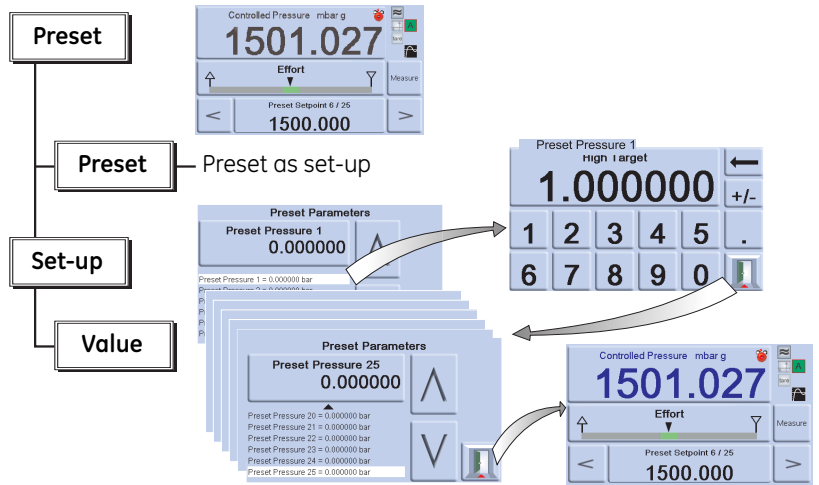

3.6 Global Set-up Selections

Global set-up selections provide access to the instrument's settings for both measure and control modes.

The set-up menu that follows provides PIN-protected access to the supervisor set-up and calibration.

Pressing Global Set-up from measure or control set-up menu changes the touch-screen display to show the following selections:

- Supervisor Set-up
- Calibration
- Save/Recall User Set-up
- Display

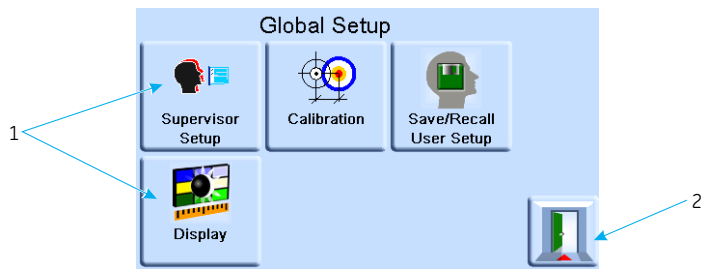

1 Selections 2 Escape Key

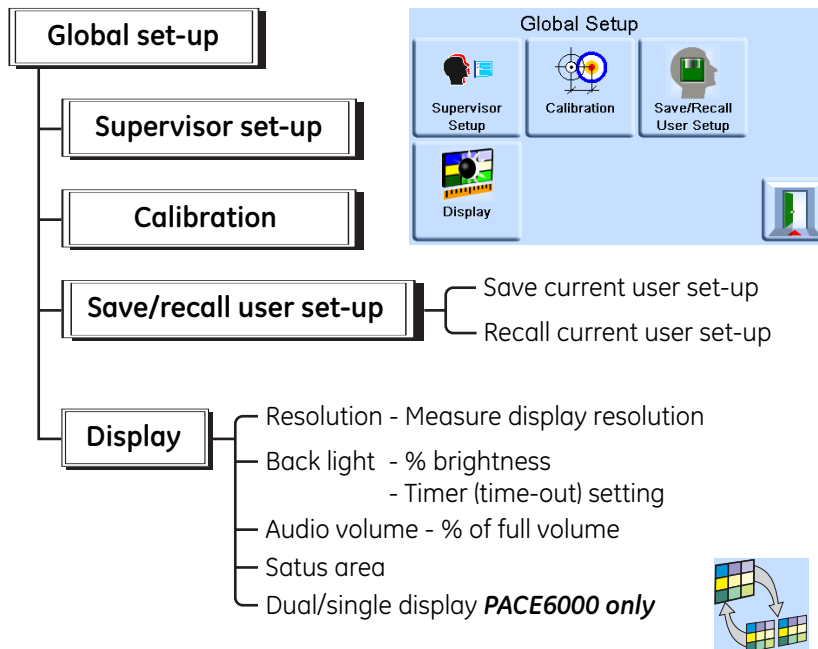

Status Area Settings

Enables the user to view an operating condition or parameter of the instrument:

- Full-scale - pressure in current selected units of the pressure range.
- Source - positive and negative source pressure values in current selected units.
- Effort meter - indicates controller effort.
- In Limits meter - indicates controller in-limits condition and time to in-limits.
- Module logic I/P - indicates status condition of logic input of control module.
- Vent and +ve FS - enables vent selection and shows full-scale pressure in current selected units.
- Zero and +ve FS - enables zero selection and shows full-scale pressure in current selected units.
- Rate - indicates slew rate set.
- Barometric - displays barometric pressure.
- Tare - indicates tare condition and value.
- Analogue Output - If option installed
- P1 - P2 - Displays Module1 pressure minus Module2 pressure (P2-P1)

Status area examples

Full-scale

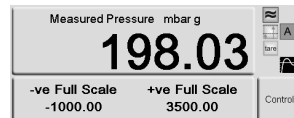

In-Limits meter

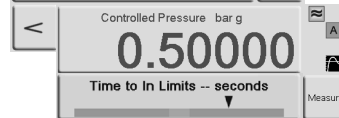

Effort meter



Vent and +ve FS



Zero and +ve FS



Barometric



3.7 Barometric Reference Option

If installed, this option allows absolute or gauge pressure range selection. To obtain absolute pressure the instrument uses a summation of gauge pressure and barometric pressure (measured by the barometric sensor). (Ref: [Section 6.8, Options](#)) and the data sheets for the performance of barometric reference and precision of absolute ranges.

3.8 Supervisor Set-up

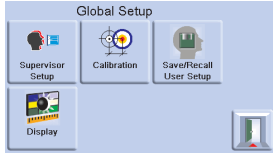
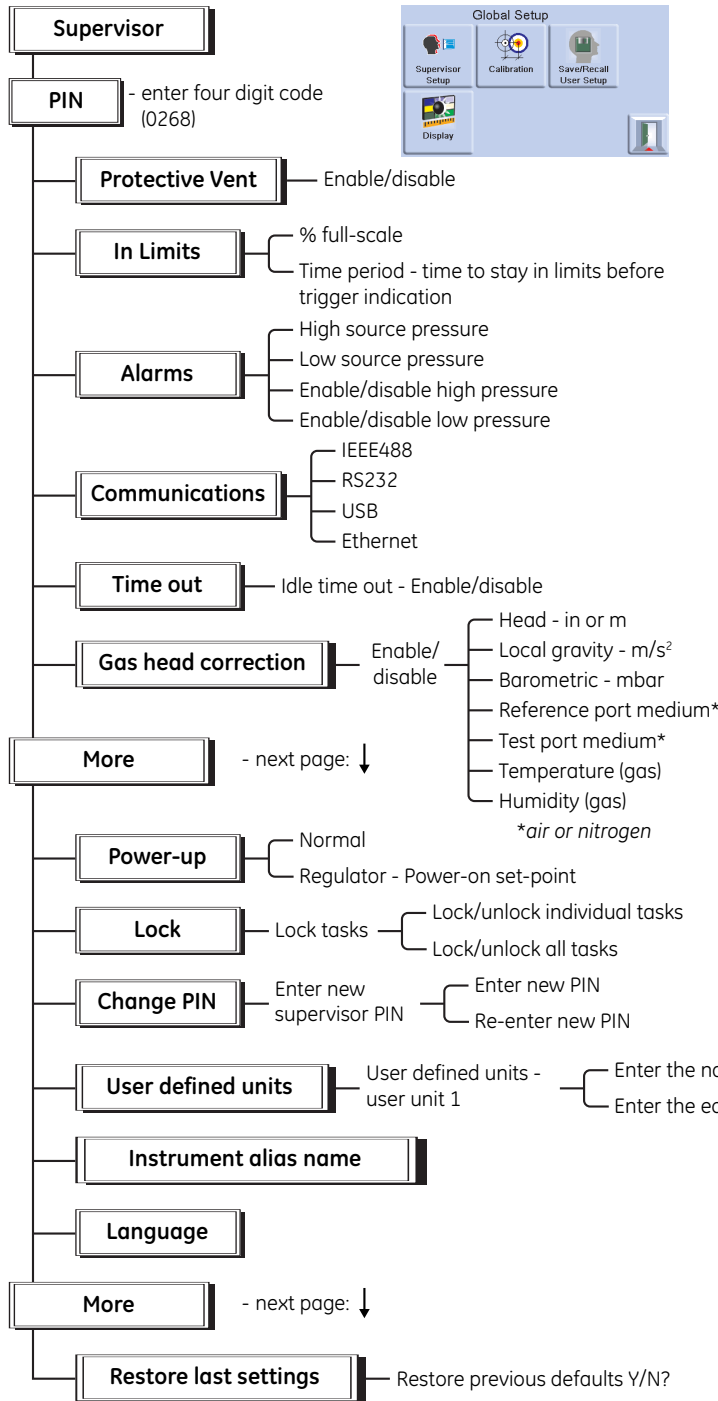

Pressing the escape key stores settings and returns to global set-up.

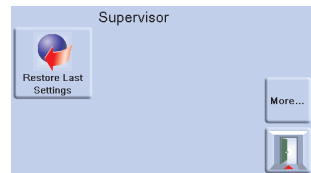
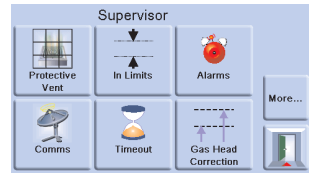

3.9 Instrument Status

The control set-up menu provides access to the status of the instrument:

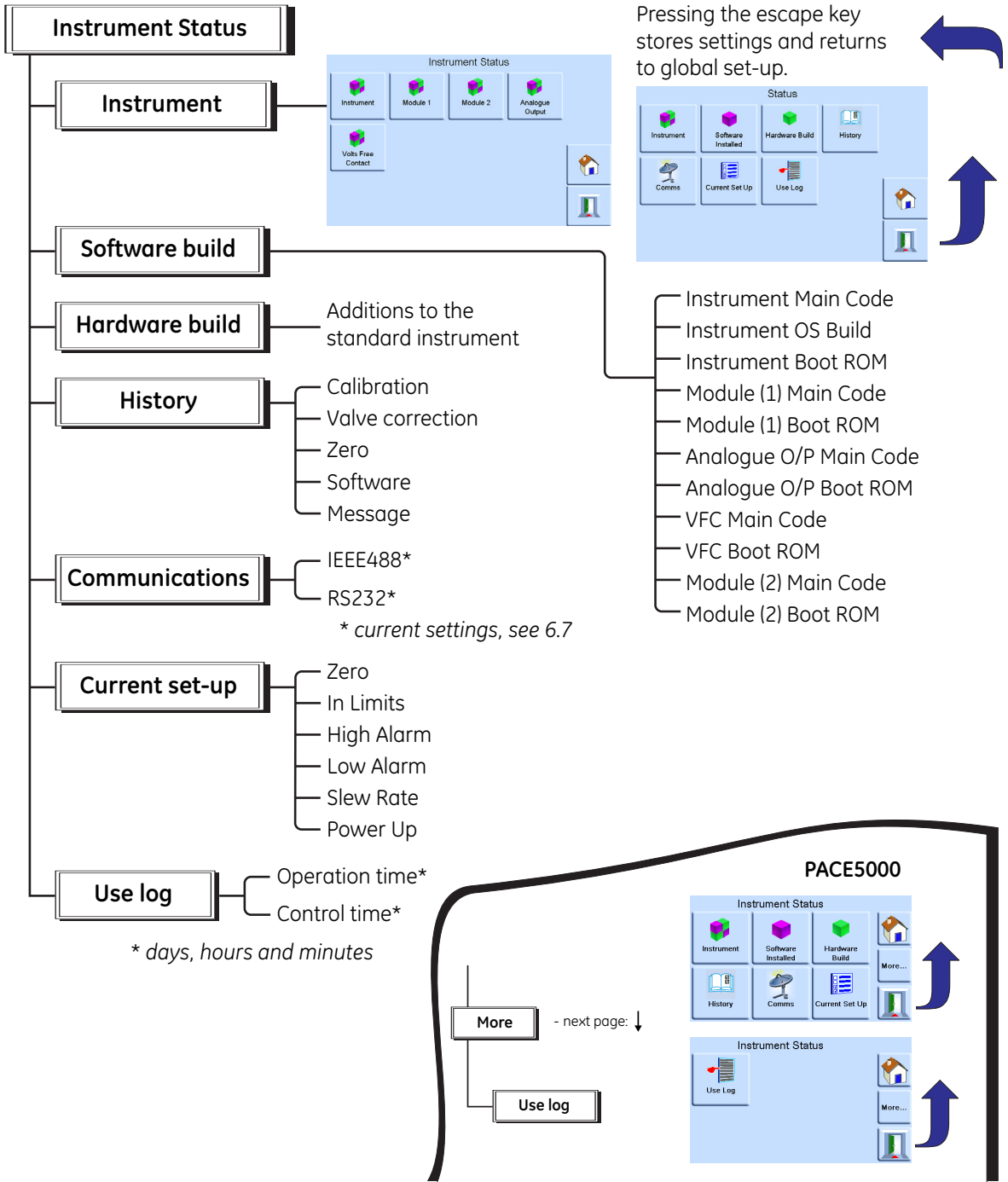

Software

Software history, in the status menu, provides read only information on the current software in the instrument.

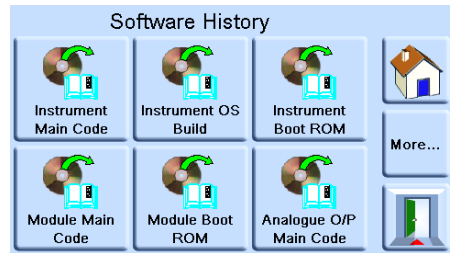
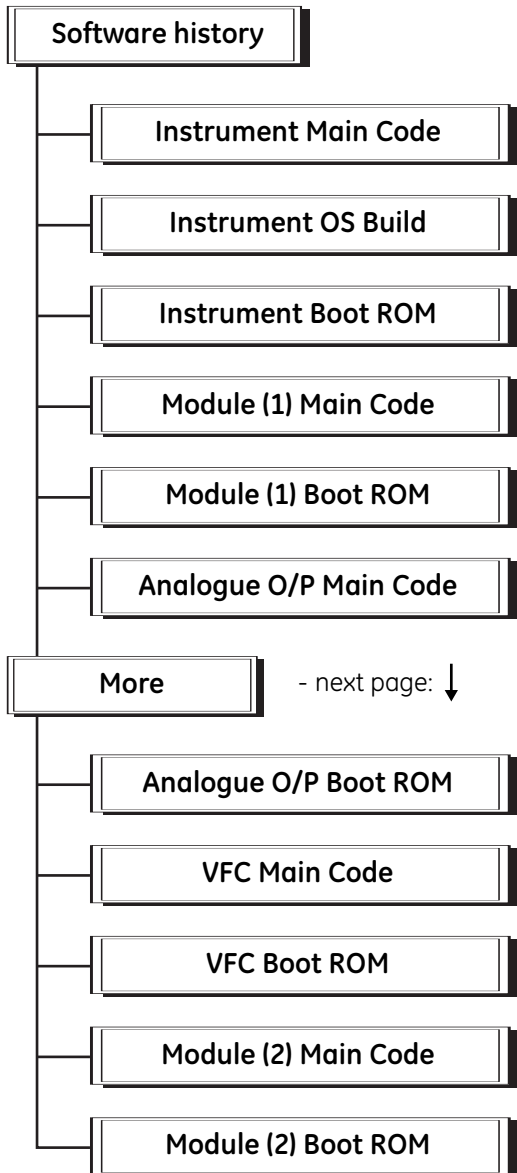

Example

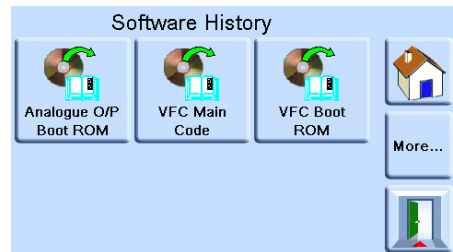
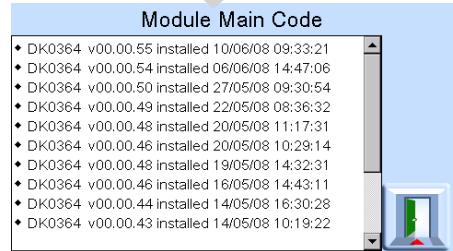

Exit set-up.



Next page of menu options.
Loops from last page to first page.

Intentionally Blank

4 Maintenance

4.1 Introduction

This section contains the routine maintenance and procedures to replace components (Ref: [Section 5, Testing and Fault Finding](#)) and listed (Ref: [Table 4-2](#)).

Task	Period
Visual Inspection	Before use
Cleaning	Weekly*
Test	Before use
Calibration	12 months †
Pressure Module filters	Determined by usage.
Replace Pressure Module	Pressure controller operating hours.

Table 4-1 Maintenance Tasks

* may change depends on usage (e.g., rack mounted, bench top) and environment (e.g., humidity, dust).
 † may change depends on the required accuracy.

4.2 Visual Inspection

Inspect for obvious signs of damage and dirt on the following:

1. External of the instrument.
2. Power supply connector and power lead.
3. Associated equipment.

Damaged parts must be replaced contact GE Service.

4.3 Cleaning



CAUTION

DO NOT USE SOLVENTS FOR CLEANING.

Clean the front panel with a damp lint-free cloth and mild detergent.

4.4 Test

Do a standard serviceability test ([Ref: Section 5.2, Standard Serviceability Test](#)).

4.5 Calibration

The instrument should be returned to the manufacturer or calibration facility, ([Ref: Section 6.12, Return Goods/Material Procedure](#)).

To find the date of the last calibration, press Measure set-up/Status/Calibration history.

4.6 Replacement Parts

Use only the replacement parts listed ([Ref: Table 4-2](#)).



WARNINGS

TURN OFF THE SOURCE PRESSURE AND CAREFULLY VENT THE PRESSURE LINES BEFORE DISCONNECTING THE PRESSURE LINES FOR MAINTENANCE. PROCEED WITH CARE.

ISOLATE THE INSTRUMENT POWER SUPPLIES BEFORE REPLACING PARTS, WITH POWER APPLIED THE INSTRUMENT CONTAINS LETHAL VOLTAGES.

Part number	Description
-	Fuse T2AH250V (PACE5000)
-	Fuse T5AH250V (PACE6000)
IO-FILTER-KIT	Kit, filter
CMX-XXXX †	Module, pressure control

Table 4-2 Replacement Parts List

† refer to data sheet

Fuse Replacement ([Ref: Figure 4-1](#))

([Ref: Section 5, Testing and Fault Finding](#)) when to replace the fuse.

Remove fuse

1. Set the power switch to OFF (if not rack-mounted got to step 3).
2. For access to rack-mounted instruments, the following actions maybe required:
 - a. Partially or completely withdraw the instrument.
 - b. Isolate pneumatic supplies.
 - c. De-pressurise all pressure supply inlet and output lines.
3. Isolate the power supply to the instrument and disconnect the IEC power supply connector (1).
4. Remove the fuse carrier (2) from the power supply input socket assembly.
5. Remove the fuse cartridge (3).

Replace fuse

1. Check for the correct type of fuse ([Ref: Table 4-2](#)).
2. Replace the fuse.
3. Refit the fuse carrier (2) in the power supply inlet socket assembly.
4. Refit and reconnect rack-mounted units ([Ref: Section 2, Installation](#)).
5. Switch on the power supply and set the power supply switch to ON.
6. If the fuse blows immediately with power-on, contact the manufacturer or Service Agent.

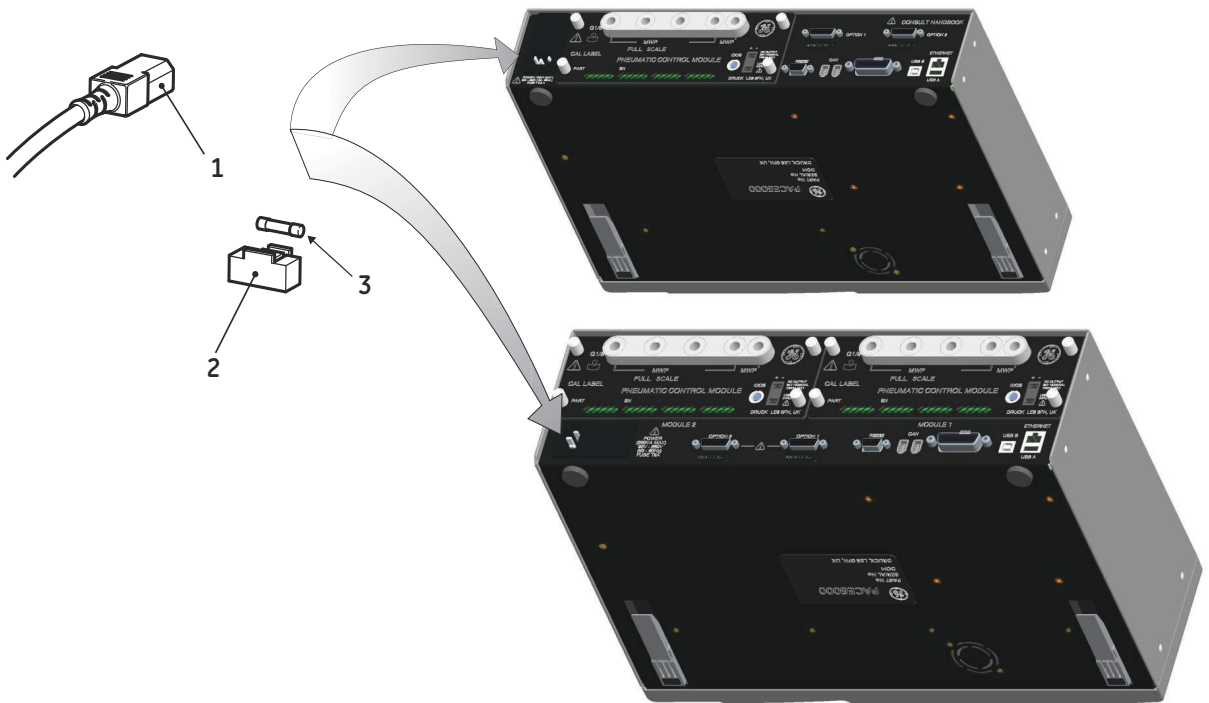

- 1 - IEC connector 2 - Fuse carrier 3 - Fuse

Figure 4-1 Fuse Replacement

Filter Replacement (Ref: Figure 4-2)

Remove filter

1. Set the power switch to OFF (if not rack-mounted got to step 3).
2. For access to rack-mounted instruments, completely withdraw the instrument from the rack.
3. Depressurize the system and isolate the pneumatic supplies.
4. Set to off and then disconnect the electrical power supply.
5. Disconnect the pneumatic pipes to the pressure module.
6. Release the four cross-head screws (drive size 2) securing the pressure module in the instrument case.
7. Remove the pressure module to access to the filters.
8. Use a 5 mm hexagonal key, to release the filter retainer (1).
9. Remove the five filters (2), if necessary, invert the pressure module to aid removal.



Figure 4-2 Pressure module filters

Replace filter

1. Insert a new filter in each of the pressure connection.
2. Use a 5 mm hexagonal key, to secure each filter retainer (Do not over tighten).
3. (Ref: Section 2, Installation).

Pressure Module Replacement (Ref: Figure 4-3)

**WARNING**

TURN OFF THE SOURCE PRESSURE AND VENT THE PRESSURE LINES BEFORE DISCONNECTING OR CONNECTING THE PRESSURE LINES. PROCEED WITH CARE.

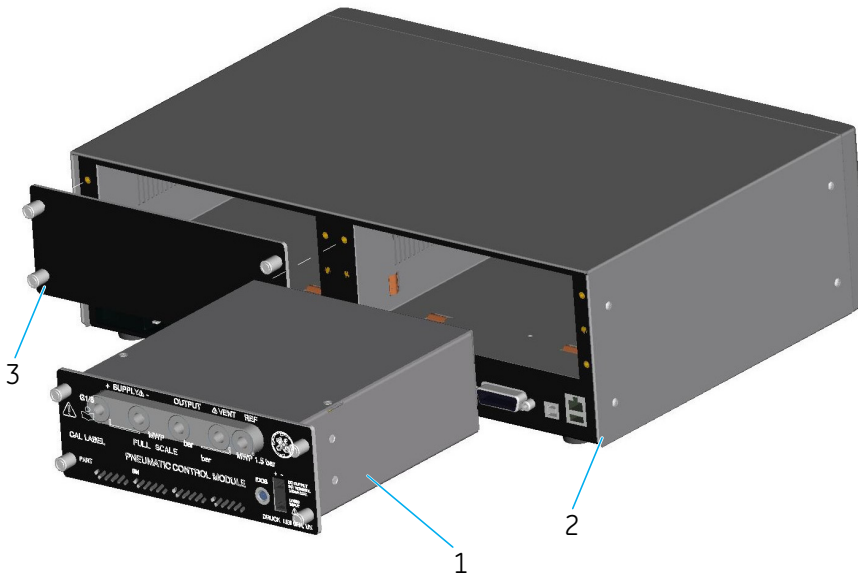

1 - Pressure module 2 - Instrument case 3 - Blanking plate

Figure 4-3 Pressure module

Remove pressure module

1. (Ref: Section 2, Installation).
2. Fit the blanking plate (supplied) to protect the internal components.

Replace pressure module

1. Fit a fully compatible pressure module (1) into the instrument case (2).
2. (Ref: Section 2, Installation).

Intentionally Blank

5 Testing and Fault Finding

5.1 Introduction

This section details the standard serviceability test. (Ref: [Table 5-1](#)) for possible faults, and the response.

The PACE instrument contains a self-test and diagnosis system that continuously monitors the performance of the unit. At power-up, the system performs a self-test.

5.2 Standard Serviceability Test

The following procedure shows if the unit is serviceable and checks functions and facilities of the PACE instrument.

Procedure

1. Connect the instrument ([Ref: Section 2, Installation](#))
2. Connect a pressure measurement device to the output port.
3. After power-up, select measure set-up.
 - a. Select the required units of pressure measurement from the measure set-up menu.
 - b. Press the status area to enter control set-up.
 - c. Select the effort meter.
 - d. Select the required control slew rate and vent rate.
 - e. Press set-point and, using the numeric keys, set a value within the pressure range of the instrument.
 - f. Check the screen display shows the following:
 - Selected units of pressure measurement
 - Selected type of slew rate
 - Set-point
 - g. Press the **Control** key to start
4. The screen display changes as follows:
 - a. The measured pressure digits change from black to blue and indicates the pressure value changing towards the set-point.
 - b. If enabled, the effort meter indicates the work effort of the controller.
5. When the controller achieves the selected pressure set-point, the screen display changes as follows:
 - a. The colour of the displayed pressure value changes from blue to green indicating that the controller is within the in-limits tolerance.
 - b. If enabled, the effort meter shows the controller effort to keep the pressure at the set-point.
 - c. Check the pressure measurement device indicates the approximate pressures generated by the PACE controller.
6. Select vent and the pressure reduces to atmospheric pressure at a controlled rate (vent rate).
7. The test is completed when the controller is at atmospheric pressure.

Testing and Fault Finding

Note:

- The vent valve opens and remains open until OK is pressed.
- Always use the vent function before disconnecting pressure equipment from the output port.
- The instrument automatically returns to measure mode.
- The colour of the displayed pressure value changes to black.

5.3 Fault Finding

Check the faults and responses (Ref: Table 5-1) before contacting www.gemeasurement.com or a GE recommended Service Agent

Fault	Response
Power supply connected, display not lit.	Check rear panel switch set to on. Check fuse and, if necessary, replace Check electrical power supply fuse or circuit breaker.
24 V DC output intermittent.	Over-load internal self-resetting fuse operating. Reduce load current to specified value.
Instruments functions, but does not reach all set-points.	Check pneumatic supplies for correct pressures. Check system for leaks.
In measure mode with output port sealed, the pressure continues to increase or decrease.	Increasing pressure, leaking Apply control valve. Decreasing pressure, leaking Release control valve. Confirm by isolating pressure supplies. Contact GE approved service agent.
Display pressure reading in red	Over-range, use vent de-pressurize or vent manually.
Instrument enters measure mode without user request or command.	Idle time-out enabled but timeout period setting too short.
Instrument will not zero.	Blocked vent port. Check for blockage. Contact approved service agent for repair.
Instrument controlling to set-point, no pneumatic output	Blocked isolation valve. Contact approved service agent for repair.
Erratic or inaccurate zero	Leaking isolation valve. Reference port restrictor not fitted. Contact approved service agent for repair.
Increased gas consumption. Unstable control at set-point or does not achieve set-point.	System leak. Carry out leak test. Contact approved service agent for repair. Reference port restrictor not fitted.
If the controlled pressure stays within the tolerance band and the pressure at the output is within limits. If the controller status indicator is outside the tolerance band,	Leak in the system or the supply pressure differs from the pressure for which the control valves have been characterised.

Table 5-1 Fault Diagnosis

Testing and Fault Finding

5.4 Approved Service Agents

For the list of service centres logon to www.gemeasurement.com

6 Reference and Specification

6.1 Installation Notes

The PACE instrument pressure controller/calibrator requires an independent pressure supply and set of connections. The exception is the reference connection, this provides a reference to atmosphere for gauge sensors and barometric sensors.

The instrument must have the correct supply pressure and a suitable supply medium. Refer to data sheet specification.

The type and density of the supply gas does not affect the accuracy of pressure measurement, assuming that the Unit Under Test (UUT) is at the same height as the controller or gas head correction is accurately set.

Gas Supply

For normal operation the instrument requires a positive supply of at least 110% of range but less than the MWP, with a gas regulator.

For absolute operation, negative gauge operation or, if the installation requires a fast response around atmospheric pressure, a vacuum source must be connected to the negative supply. For recommended configurations (Ref: Figure 2-4), (Ref: Figure 2-5) & (Ref: Figure 2-6).

To achieve control performance the source pressure must be maintained at 10% full-scale above the required set-point.

Controller performance is maintained during slow variations in source pressure down to a source pressure of 20% full-scale range.

Supply Conditioning Equipment

Supplies should be provided with an isolation valve and any other necessary conditioning equipment.

Note: To protect the control module, for ranges above 100 bar, from over-pressure a suitable protection device (such as a relief valve or bursting disc) must be fitted to limit the applied supply pressure to below the MWP.

Maximum Working Pressure

If the measured +ve source pressure exceeds the limits below then display a persistent message box as shown.

Clear this message by selecting "OK".

Supply Contamination

Supplies may need the removal of water, oil or particulate contamination. Any water in the compressed gas supply will be in vapour form, i.e. non-condensing and must be removed

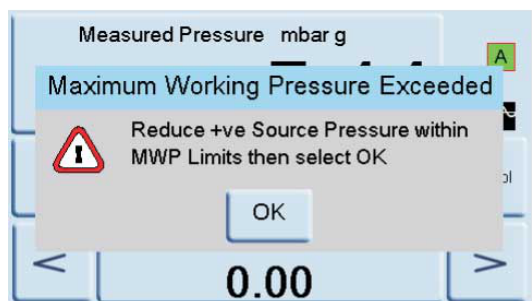

Reference and Specification

using a mist filter.

Oil must be completely removed as this causes a rapid deterioration of the control valve performance.

The compressed gas supply must not contain particulates and must be removed using a particulate filter. Do not use a compressed gas supply containing corrosive material.

Systems without a Negative Supply

Without a negative supply (vacuum pump), release the positive pressure from the system to atmosphere through the negative supply port.

The release from the negative port must be piped away to where the discharge causes no disturbance or hazard. A diffuser may be fitted to the negative supply port to diffuse air flow.

The need for a Negative Supply (for Optimum Performance)

General

Supply pressures (at least 110% of range but less than the MWP) there must be a difference of 10% of full-scale between the supply pressure and the maximum output pressure. When operating at positive or negative full-scale, there must be a pressure difference between supply and output to cause a gas flow.

Operating near atmospheric pressure or below

Any controller operating near atmospheric pressure or below requires a vacuum pump or other negative supply connected to the negative supply port for optimum performance.

Without a vacuum supply, as the output pressure approaches atmospheric pressure, the differential pressure approaches zero resulting in a reduced flow to the output.

Reduced flow causes an increase in the time to control to atmosphere, especially with large user volumes, and an increased overshoot at low pressures, ([Ref: Figure 2-4](#)), ([Ref: Figure 2-5](#)) & ([Ref: Figure 2-6](#)).

Vacuum Pump

Each PACE Control Module has a vacuum sensor. Connect a vacuum pump to the -ve supply port. The higher the flow rate of the vacuum pump the better the PACE control performance.

Low pressure ranges <700mbar require vacuum regulation or the use of the negative gauge pressure generator IO-NEG-G-GEN-1 option.

Conclusion

Use a vacuum supply for:

Absolute ranges.

Negative gauge ranges.

A vacuum supply improves:

Time to reduce system pressure at pressures below 2 bar (30 psi), full-scale.

Control stability near atmospheric pressure.

Overshoot at low pressures.

To improve performance at or near gauge zero.

Values of air density (kg m^{-3}) for air of relative humidity 50% and containing 0.04% carbon dioxide by volume.

Air pressure (kPa)	Air temperature (°C)						
	14	16	18	20	22	24	26
87	1.052	1.045	1.037	1.029	1.021	1.014	1.006
88	1.064	1.057	1.049	1.041	1.033	1.025	1.018
89	1.077	1.069	1.061	1.053	1.045	1.037	1.029
90	1.089	1.081	1.073	1.065	1.057	1.049	1.041
91	1.101	1.093	1.085	1.077	1.069	1.061	1.053
92	1.113	1.105	1.097	1.089	1.080	1.072	1.064
93	1.125	1.117	1.109	1.100	1.092	1.084	1.076
94	1.137	1.129	1.121	1.112	1.104	1.096	1.088
95	1.149	1.141	1.133	1.124	1.116	1.108	1.099
96	1.162	1.153	1.145	1.136	1.128	1.119	1.111
97	1.174	1.165	1.156	1.148	1.139	1.131	1.123
98	1.186	1.177	1.168	1.160	1.151	1.143	1.134
99	1.198	1.189	1.180	1.172	1.163	1.154	1.146
100	1.210	1.201	1.192	1.184	1.175	1.166	1.158
101	1.222	1.213	1.204	1.196	1.187	1.178	1.169
102	1.234	1.225	1.216	1.207	1.199	1.190	1.181
103	1.247	1.237	1.228	1.219	1.210	1.201	1.193
104	1.259	1.249	1.240	1.231	1.222	1.213	1.204
105	1.271	1.261	1.252	1.243	1.234	1.225	1.216
106	1.283	1.274	1.264	1.255	1.246	1.237	1.228

Table 6-1 Air Density Values

Note: 100 kPa = 1 bar

6.2 Operational Requirements



CAUTION

A CONTAMINATED UUT MUST HAVE ADDITIONAL IN-LINE FILTERS CONNECTED BETWEEN THE OUTPUT PORT AND THE UUT TO PREVENT CONTAMINATION OF THE INSTRUMENT.

Negative or Vacuum Supply

The negative supply for absolute control does not need to be regulated. Any variation between this and absolute zero will affect instrument operation if controlling at low absolute pressures.

Oil Contamination

Precautions must be taken against oil transfer to the instrument.

Recommended

1. A normally-open venting solenoid connected to atmosphere and the pump. When the pump supply is switched off, the valve opens allowing atmospheric pressure to enter the pump directly rather than through the pipe to the instrument.
2. If the above is not done, oil may progressively move up the supply pipe and into the instrument.

Pump Performance

Recommended for ranges above 2 bar (30 psi) gauge, positive full-scale

1. When installing a vacuum supply protect the vacuum pump against the discharge of positive pressure by the controller into the vacuum pump. This may result in reducing vacuum pump performance.
2. Use a check valve in the negative supply to vent excess pressure to atmosphere if the vacuum pressure rises above atmospheric pressure. The check valve should be installed on the instrument side of a volume which is approximately equal to the system volume. The volume slows any rapid pressure rise giving the vacuum pump time to reduce the pressure.

Note: A wide bore vacuum pipe can have enough volume and, used with a check valve, could provide the necessary overpressure protection.

Venting

Either a zero or vent operation uses the vent port.

Vent

The system gas at the output pressure can be released from the vent port. Unrestricted gas flow occurs in this operation.

Recommended

Use a controlled method to reduce the system pressure, at a controlled rate, to near atmospheric pressure then select vent.

Zero

During a zero operation only the internal volume of the instrument vents to atmosphere.

Recommended

Do not obstruct the vent port. To diffuse gas exhaust, a diffuser may be fitted to the vent port.

Output Port

The output port provides the controlled test pressure to the UUT.

Reference Port

The reference port provides the negative pressure to the gauge sensor and to the barometric reference (option). Gauge sensors use this port identified as "REF". For gauge sensors (without a barometric reference) small pressures can be applied. Refer to MWP stated on the rear panel of the control module. All other pressure measurement requires the port to be opened to atmosphere.

When in gauge mode, the instrument shows and controls the pressure difference between the reference port and the output port.

Note: This is not a true differential operation as there is no true differential calibration of the sensor.

The transducer of the barometric reference option senses atmospheric pressure through the reference port, when enabled the port must be open to atmosphere.

The reference connection should be used (differential connection option) for precision low pressure measurement. The instrument controls pressure relative to the pressure at the reference port. An atmospheric pressure change causes the controller to adjust the pressure and appears at the pressure output as apparent instability. To keep a stable controlled pressure, the reference port should be restricted. Using a reference port restrictor, short term ambient pressure variations can be prevented from affecting controller performance.

The controller and UUT references should be connected together (using the optional differential connection kit) to provide a common reference to atmosphere.

Reference and Specification

6.3 Icons







































Icon	Function	Icon	Function	Icon	Function
	Active		Aero mode		Airspeed range
	Alarm		Altitude range		Area of use
	Asterisk		Auto range		Audio volume
	Auto zero		Backlight		Calibration
	Calibration history				Change supervisor PIN
	Communications		Contrast		Control mode
	Copy		Correction analogue output		Correction SCM
	Correction sensor		Correction source sensor		Correction valve
	Current set-up		Date & time		Delete
	Diagnostic analogue output		Diagnostic barometric option		
	Diagnostic control sensor		Diagnostic controller		Diagnostic general
	Diagnostic RS232		Diagnostic source sensor		Diagnostic vacuum sensor
	Diagnostic volt-free		Diagnostics		Display
	Divider		Error		Escape

Table 6-2 Display Icons in Set-up Menus

Icon	Function	Icon	Function	Icon	Function
	Exclamation		Fault history		Gas head pressure
	Gauge mode		Global set-up		Go-to-ground
	Hardware build		Home		Idle time-out
	IEEE488		Information		In limits
	Instrument		Instrument accuracy		Instrument alias name
	Language		Leak test		Lock
	Lock tasks		Logic output		Max-min
	Max peak		Min peak		Nudge
	Passive mode		Percentage		PIN
	Power-up		Preset		Pressure
	Pressure filter		Process		Protective vent
	Question		Range		Recall user set-up
	Reset use log		Resolution		Re-try
	Roughing		RS232		Restore to as shipped settings

Table 6-2 Display Icons in Set-up Menus

Reference and Specification

Icon	Function	Icon	Function	Icon	Function
	Restore settings 2		Run		Save as shipped
	Save recall user set-up settings		Save user set-up		Screen mode
	Screen saver		SCM filter		SCM zero
	Select range		Set-point disable/enable		Set-point limits
	Set-point higher limit		Set-point lower limit		Set date
	Set serial number		Set time		Set-up zero
	Slew rate linear		Slew rate max rate		Software build
	Software upgrade history		Software upgrade		Status
	Status area		Step (single)		Stop
	Supervisor set-up		Switch test	Tare	Tare
	Task		Test program		Test program copy
	Test program delete		Timing		Time out
	Timed zero		Units		User defined units
	Use log		Use log history		Vent

Table 6-2 Display Icons in Set-up Menus







Icon	Function	Icon	Function	Icon	Function
	Vent time out		Vent Yes/No		Vent set-up
	Warning		Zero analogue output		Zero history
	Zero				

Table 6-2 Display Icons in Set-up Menus

6.4 Measure Set-up

Pressure Zero

During use, the instrument pressure sensor can show small zero shifts caused by time and temperature changes. Regular “zeroing” increases measuring precision.

Process

Selects display processing features that change the reading, as follows:

- %: Pressure can be expressed as a percentage of full-scale or as a percentage of a specified span.
- Filter: The reading can be filtered by a custom low pass filter or the filter can be disabled **(default disabled)**. The controller works at a speed independent of the filter time constant. A specific tare value can be selected or the current displayed pressure reading can be “captured” as the tare value. The display shows the selected tare value in the pressure window.
- Tare: “captured” as the tare value. The display shows the selected tare value in the pressure window.

Task

Selecting Task enables a set of pre-determined functions and software enabled optional functions.

Units

Select the new units from the list of pressure measurement units. Special units can also be defined (Ref: [Section 6.7, Supervisor Set-up](#)).

Global set-up

(Ref: [Section 6.6, Global Set-up](#)).

Set-up Zero

- Mode = off/auto/timed
- Interval = 00.00.00
- Isolation status = isolated/non-isolated.

6.5 Control Set-up

Vent

Select **Vent** to reduce the system pressure to near atmospheric pressure. Use this feature to reduce system pressure to a safe value before disconnecting the UUT. Use vent set-up to adjust the slew rate of venting.

Note: The vent key can be selected in the control set-up menu or programmed as an on-screen selection in the status area from the global set-up/ display/status area menu.

Nudge

Sets the incremental resolution of the nudge control for trimming the set-point digits.

Set-point Limits

Defines the limits of pressure that can be entered as a set-point (used for protecting sensitive UUT).

Slew Rate

Sets how the controller achieves a set-point.

Max Rate	Setpoint step changes to new setpoint
Linear:	Controller changing pressure linearly to set-point at a rate set by user.
Rate:	Either maximum rate or at a rate (value) set by user.
Overshoot:	Fast changing pressure may go beyond set-point.
No overshoot:	Changing pressure at an exponential rate but remaining within limits.
Note:	This function should be used for UUT that have hysteresis errors.

Control Mode

Selects one of the three modes that follow:

Active Control

In this mode, the controller continuously maintains the set-point, compensating for small pressure leaks and thermal affects.

Passive Control

In this mode, the user can define a band either side of the set-point, the default band equals to the instrument's precision. When the controlled pressure enters this band, the controller automatically shuts-off. If the measured pressure exits the band, the controller automatically re-establishes the pressure, without instability, the controlled pressure re-enters the band.

Note: If passive mode is in use with a leak free and thermally stable system then the control stability contribution can be discounted from the uncertainty calculation.

Zero Gauge Control

The controller switches off once stable at zero gauge and the zero valve opened. Entering a new set-point causes the zero valve to close and the controller starts to control to the new set-point.

Global Set-up

PIN protected menu ([Ref: Section 6.7, Supervisor Set-up](#)).

Status

The display shows the following:

- a. Instrument
 - Module 1 (Module 2 if fitted)
 - Control sensor
 - +ve source sensor
 - -ve source sensor
 - Barometric sensor (Optional)
- b. Software build - read only data
- c. Hardware build - read only data
- d. History - read only data
- e. Communications
- f. Current set-up - read only data
- g. Use log - read only data
- h. Software options - read only data
- i. Summary - read only data.

Vent Set-up

Use the vent set-up to prevent damage to rate-sensitive equipment connected to this controller. The vent slew rate setting is independent of the controller slew rate settings.

6.6 Global Set-up

Supervisor Set-up

PIN protected menu ([Ref: Section 6.7, Supervisor Set-up](#)).

Calibration

PIN protected menu.

Save/Recall User Set-up

Save user set-up

Recall user set-up

Display

Resolution

Backlight

Audio volume

Status area

Screen mode (PACE 6000 only)

6.7 Supervisor Set-up

The Supervisor menu provides facilities for programming settings. These are made during installation as follows:

Note: A PIN protects the Supervisor menu against unauthorised use. Each instrument on delivery contains the factory set PIN (0268). To continue protecting the supervisor set-up menu the PIN should be changed as soon as possible.

Protective Vent

The protective vent can be enabled or disabled and causes the discharge of pressure at a controlled rate if the measured pressure exceeds 110% full-scale. This protects the pressure sensor from over-range.

The Power-up trapped pressure vent can be enabled or disabled from the protective vent menu.

In Limits

A tolerance value can be set at the set-point. When the controller achieves the set-point, the instrument controls within this set tolerance value. It does not affect controller stability or precision. The instrument uses the 'in limits' flag when performing a control task such as Leak Test or Switch Test.

Note: In remote control, the control computer can be used to interrogate the 'in limits' register to confirm the controller has achieved set-point.

Alarms

An alarm can be set to trigger when the pressure exceeds the high alarm or falls below the low alarm. A buzzer sounds when the alarm triggers and the alarm symbol (bell) appears on the display.

Comms

Selects a communication port parameter. Simultaneous operation of both the RS232 and the IEEE 488 interfaces is fitted as standard.

The user can select appropriate settings for communicating with the control computer (PC) and the required command protocol. Refer to K0472, SCPI Remote Communications Manual or K0469 Heritage Communications Manual.

RS232

Located on the rear panel an external RS232 connection requires the following:

Connector	9-way 'D' female wired as per Table 2-1
Communications	RS232 point-to-point only (DPI 520 daisy chain is not supported)
Baud Rate power-up default	9600, no parity & handshake = xon/xoff
Baud rates selectable **	2400, 4800, 9600, 19k2, 38k4, 57k6 & 115k2
Parity	None, Odd & Even
Flow control	None, Hardware & xon/xoff
Protocols †	SCPI, DPI 500, DPI 510, DPI 515, DPI 520
New data up-date rate	refer to data sheet
Built-in EMC Filtering and Transient voltage protection	
** Selectable through the user interface	† Not all protocols available on all models.

IEEE 488

Located on the rear panel an external IEEE 488 connection requires: the following:

Connector	24-way 'D' female wired as IEEE 488 standard
Communications	IEEE 488 GPIB
Default Address	16
Protocols †	SCPI, DPI 500, DPI 510, DPI 515, DPI 520
New data up-date rate	refer to data sheet
Built-in EMC filtering and transient voltage protection.	
† Not all protocols available on all models.	

Ethernet

Located on the rear panel an external Ethernet connection requires the following:

Connector	Ethernet RJ45
Protocol	SCPI
Terminator	CR/LF
Default Address	Auto IP (0.0.0.0)
Host name	PACExxxxxx (where xxxxxx = serial number)
Web Password	0268
Access control	Open
Reset LAN Settings	Selected in Supervisor set-up menu

Reference and Specification

Ethernet Firewall

A firewall protects the Ethernet connection. The firewall is always turned on. The following ports are unfiltered to allow remote communication and control.

Port	Description
80/tcp	http (Web server)
111/tcp	rpcbind (RPC for VXI)
111/udp	rpcbind (RPC for VXI)
443/tcp	https (Web server)
5025/tcp	SCPI socket
*****/tcp	VXI-11 communication (dynamic port allocated)

Ethernet Parameters Range Setup

1. Touch any of the three horizontal Measure touch pads on the home screen to open the CONTROL SET UP screen
2. On the CONTROL SETUP screen, select GLOBAL SETUP.

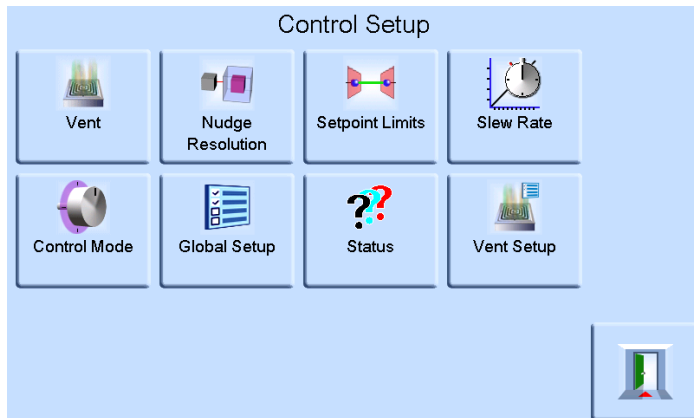

3. Select SUPERVISOR SET UP.

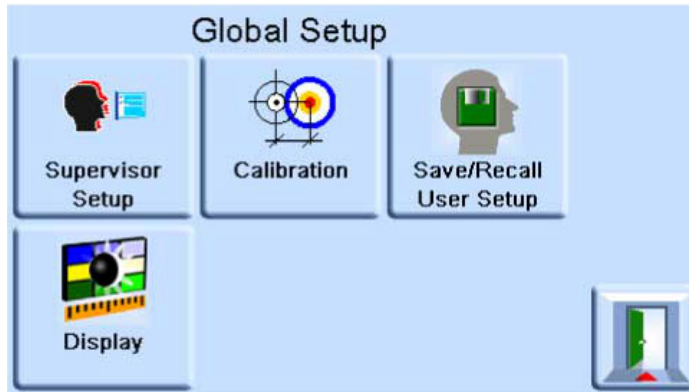

4. Enter the Supervisor PIN and press ENTER SUPERVISOR PIN. Use the back arrow in the top right corner of the screen to delete any incorrect data entries.

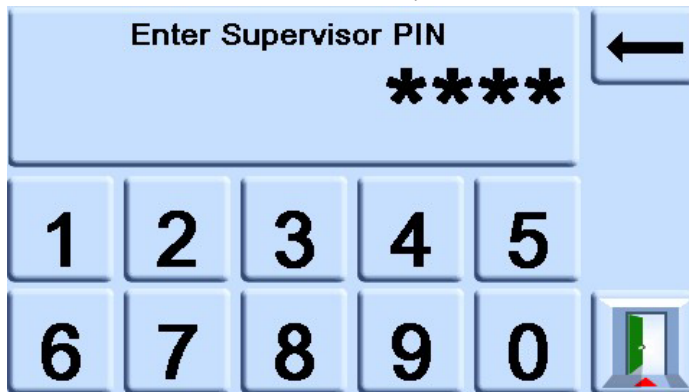

Note: The factory set Supervisor PIN is 0268. If the Supervisor PIN has been locally changed, make sure that the new PIN is kept in a safe place. If the new PIN is lost, it can only be reset at a GE Service Centre.

Reference and Specification

5. Press COMMUNICATIONS STATUS to open the COMMUNICATIONS STATUS screen.

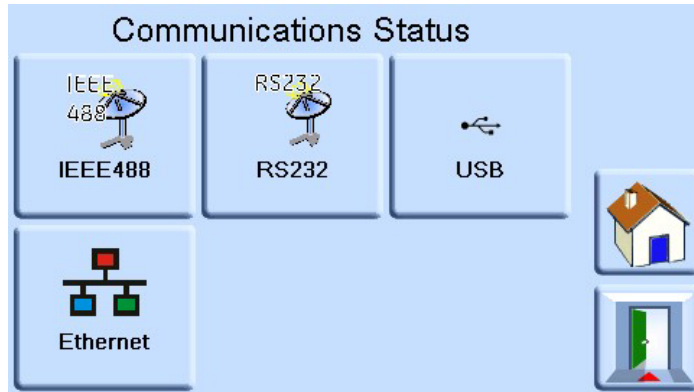

6. Select ETHERNET to open the ETHERNET PARAMETER screen.

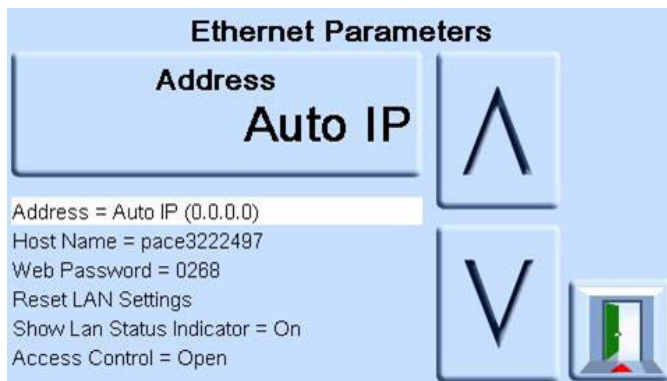

7. To change the ADDRESS parameter, complete the following:
 - a. On the ETHERNET PARAMETER screen, use the UP and DOWN arrows to highlight the ADDRESS field.
 - b. Press the top touch pad on the screen to enter the ADDRESS TYPE screen.

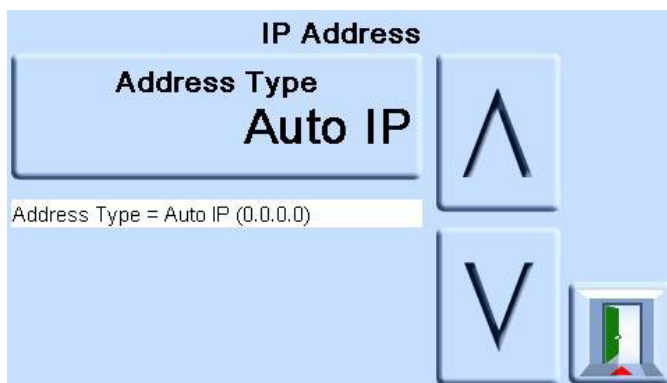

- c. Use the UP and Down arrows to highlight the desired address type (either AUTO IP or STATIC).

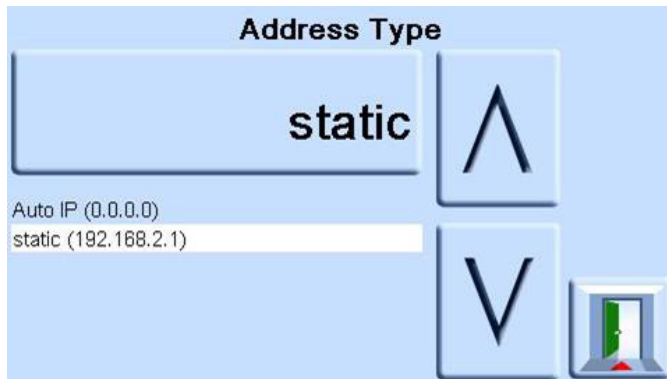

- d. Press the top touch pad on the screen to set the new address type. The screen automatically returns to the ETHERNET PARAMETERS screen.

8. To change the host name, complete the following:

- a. On the ETHERNET PARAMETER screen, use the UP and DOWN arrows on the right of the screen to highlight the HOST NAME field.

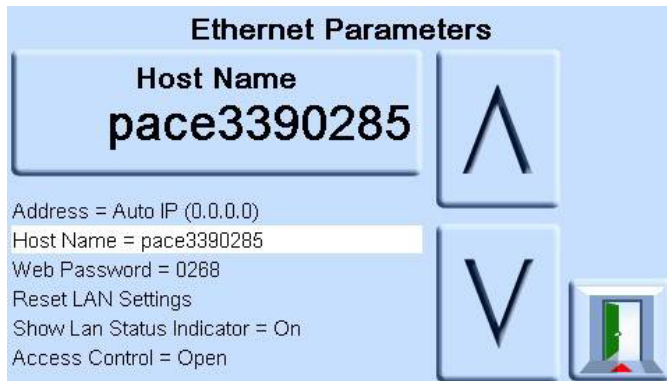

- b. Press the top touch pad on the screen to enter the HOST NAME screen.
- c. Use the keyboard to input the new host name and then press the top button on the screen to set the host name. The screen automatically returns to the ETHERNET PARAMETERS screen.



9. To change the web password, complete the following:
 - a. On the ETHERNET PARAMETER screen, use the UP and DOWN arrows on the right of the screen to highlight the WEB PASSWORD field.

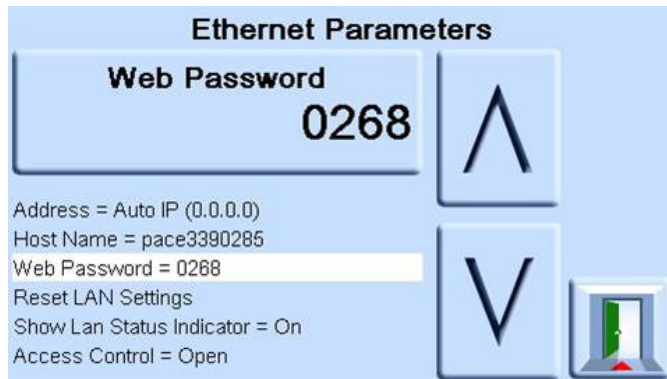

- b. Press the top touch pad on the screen to enter the WEB PASSWORD screen. The keyboard screen opens.



- c. Use the keyboard to input the new web password and then press the top touch area on the screen to set the new password. The screen automatically returns to the ETHERNET PARAMETERS screen.
10. To reset the LAN settings, complete the following:
- a. On the ETHERNET PARAMETER screen, use the UP and DOWN arrows on the right of the screen to highlight the RESET LAN SETTINGS field.
 - b. Press the RESET THE LAN SETTINGS touch pad on the top touch pad of the screen.
 - c. The RESET LAN SETTINGS sub-screen asking for confirmation of the reset. Press YES to confirm reset of the LAN settings.

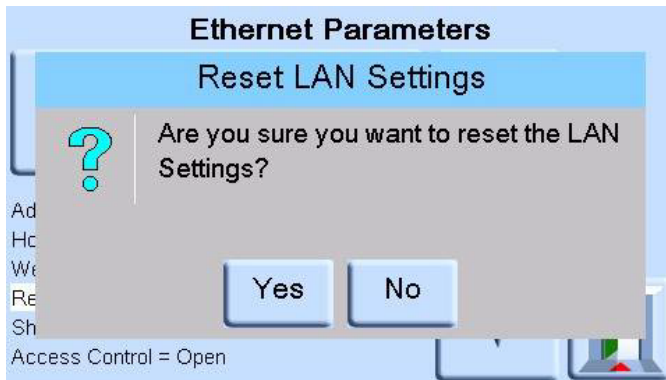

11. To turn the LAN status indicator on or off, complete the following:
- a. On the ETHERNET PARAMETER screen, use the UP and DOWN arrows on the right of the screen to highlight the SHOW LAN STATUS field.

Reference and Specification

USB

Located on the rear panel a USB connection requires the following:

Connector	USB 'B'
Protocol	SCPI
Terminator	CR, LR or CR/LF

Communications mode is selected for serial communications using the SCPI protocol.

Mass storage device is selected to mount an external USB 'A' connected mass storage device or the internal memory SD card, from a PC connected to the USB 'B' port.

External USB device has priority masking the internal memory SD card.

Note: When upgrading software make sure USB 'B' connection is disconnected.

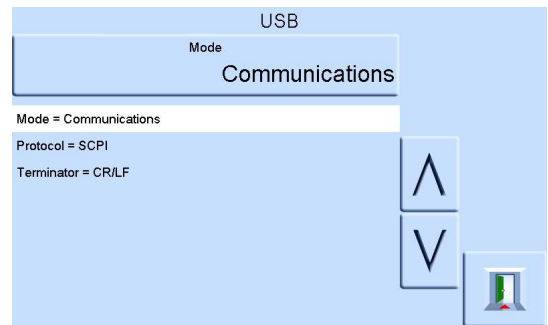
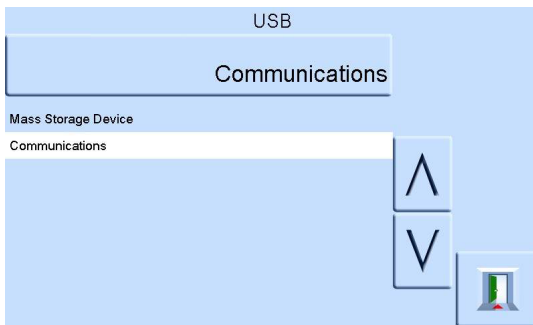
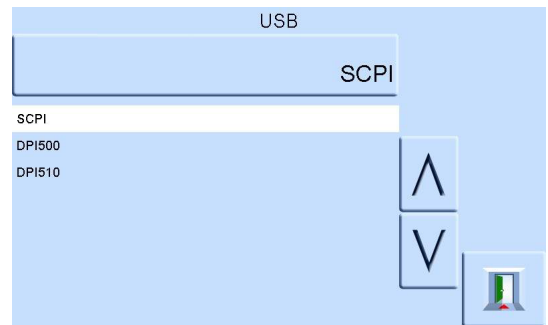
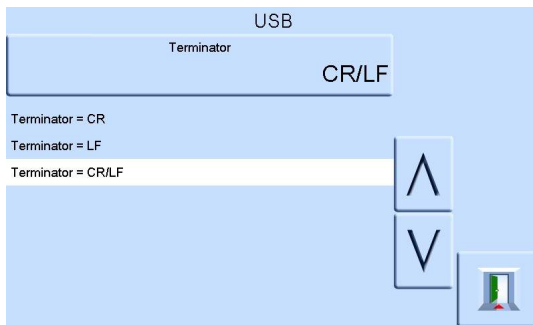

Timeout

Presets the times for automatically changing from control to measure mode.

Note: Controller timeouts can save supply gas, extending control valve life and minimising acoustic noise.

Idle Timeout

Starts when the controller achieves the set-point after the set time, if new set-points are not entered the timer will time-out and return to measure mode.

Gas Head Correction

Corrects pressure output for the height difference between instrument and UUT:

- For UUT positioned higher than the reference level of the PACE instrument enter a positive height correction.
- For UUT positioned lower than the reference level of the PACE instrument enter a negative height correction.
- When calibrating the PACE instrument disable the gas head correction and correct the actual applied pressures for height.

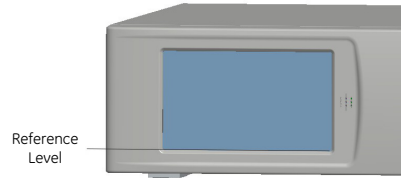

Power Up

With Normal mode selected, the instrument powers up in **Measure** mode.

With regulator mode selected, the instrument powers-up in **Control** mode at a pre-selected set-point value.

Note: When using regulator mode, disable the **Idle Timeout** feature.

Lock Tasks

Individual tasks:

Allows any combination of individual tasks to be disabled.

Note: Restricts operation of the instrument to specific tasks or functions, use for production procedures.

All:

Disables all tasks.

Change PIN

Changes the Supervisor PIN: enter the existing PIN, then the new PIN and confirmation of the new PIN.

Note: Confirmation of the new PIN permanently replaces the old PIN. Record this new PIN and keep in a safe place. If new PIN is lost it can only be reset by returning the instrument to a GE service centre.

User Defined Units

Permits the user to define a set of pressure conversion units. Following the on-screen prompts special units may be set by selecting a Pascal multiplier and assigning a five character name.

Instrument Alias Name

Permits the user to define a 20 character alias name for the instrument. The instrument

Reference and Specification

returns this name through the communications interfaces.

Language

Operation in any of the following languages can be selected:

- English (default)
- French
- German
- Italian
- Portuguese
- Spanish
- Russian
- Chinese
- Japanese

More languages can be added.

Adding a Language

Languages can be added as follows ([Ref: Figure 6-1](#))

1. Create a language file by translating from the English language file.
2. Check the pixel width of each translated word by using the PACE language check file, (download from GE Support Central PACE).
3. Create an empty DPI folder on a USB stick.
4. Create an empty “LANGUAGES” sub-folder.
5. The language file naming conventions is “Language<<language name>>.Ing”.
6. Save the language file into the languages sub-folder.
7. Use the PACE instrument software upgrade procedure to upload the language file from the USB stick into the PACE instrument.

Note: An English and French language file name would be: LanguageEnglish.Ing and LanguageFrench.Ing. Language files named “Language.Ing” or in any other format will be ignored by PACE.

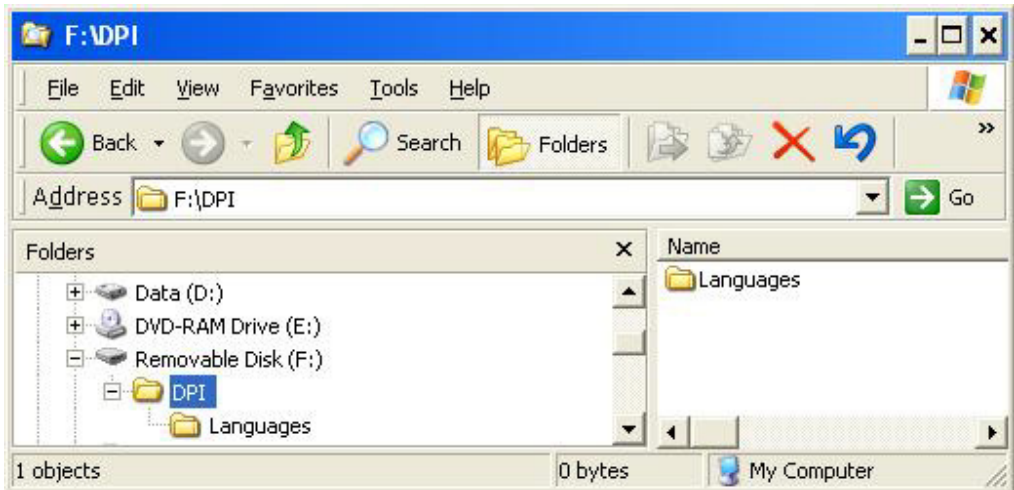
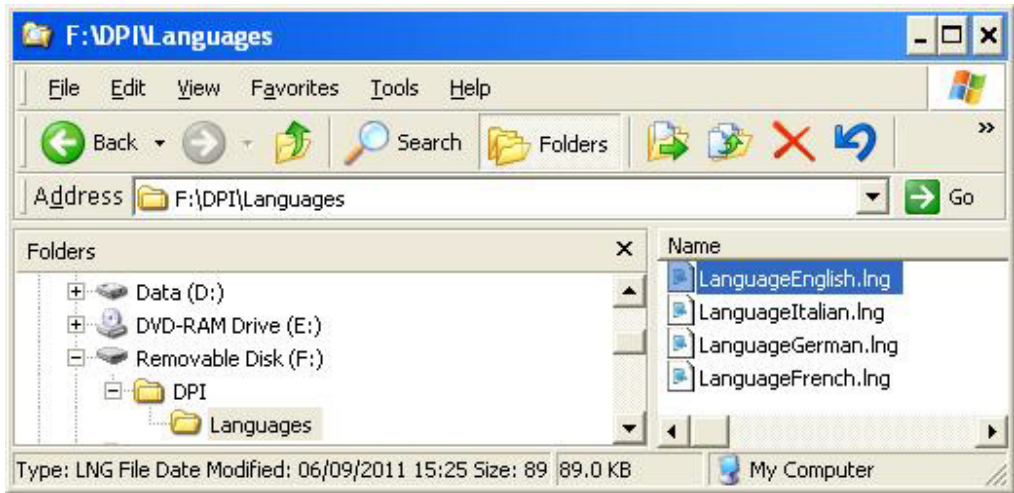

Figure 6-1 Language Setting

Restore as Shipped Settings

Restores instrument settings to factory default, but does not affect PIN settings.

6.8 Options

Option Enable Process

To enable soft options on a PACE instrument, use the following:

1. Touch the top Measure area of the screen.
2. Select Global Setup.
3. Select Calibration.
4. Enter a Calibration PIN 1234.
5. Enter new option key xxxxxxxxxxxx (10 digits).
6. After entry of this key PACE confirms the options have been enabled.

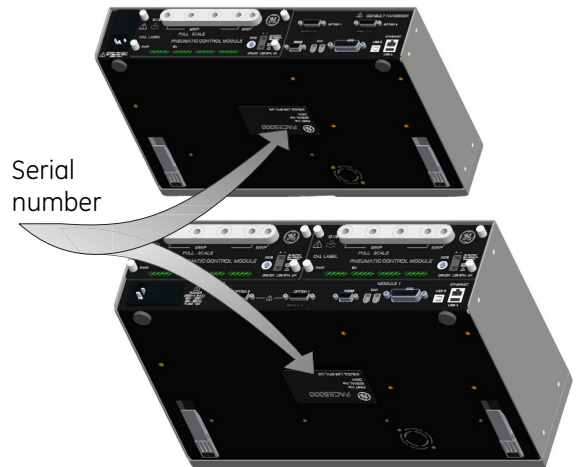

Options in the Task Menu

The following software enabled options can be selected from the task menu:

Leak Test Option

This task applies one or two test pressures to either an external system to find any leaks in a system connected to the instrument or an internal leak check. This task sets the test pressure, control dwell time at the test pressure and the leak test time (measure dwell time).

Note: If only one test pressure is required set TP1 = TP2.

At the start of the test, the instrument applies a test pressure to the user system.

A control dwell time allows the user system to thermally stabilise. The instrument changes to measured mode and then records the pressure change during measure dwell time. On completion, the display shows the leak rate results with leak rates per second or per minute in the current pressure units selected in measure set-up.

Leak test

Start

Set-up

Test pressure 1

Test pressure 2

Edit pressure

Control dwell time

Measure dwell time

Leak rate /second /minute

Measured Pressure bar g
1.499854
Test Pressure 1 = 1.500000
Test Pressure 2 = 0.054000
End Pressure = 0.000000
Control Dwell = 00:00:20
Measure Dwell = 00:00:20
Leak Rate = /second

Example set-up parameter

Leak Test Parameters
Measure Dwell
00:00:20
Test Pressure 1 = 1500.000 mbar
Test Pressure 2 = 54.000 mbar
End Pressure = 0.000 mbar
Control Dwell = 00:00:20
Measure Dwell = 00:00:20
Leak Rate = /second

Measure Dwell
00:00:20

Example leak rate results

Measured Pressure bar g
0.000392
Test Pressure 1 Start 1.499547
Test Pressure 1 End 1.499829
Leak Rate 1 0.0000417/sec
Test Pressure 2 Start 0.053895
Test Pressure 2 End 0.054107
Leak Rate 2 0.0000056/sec

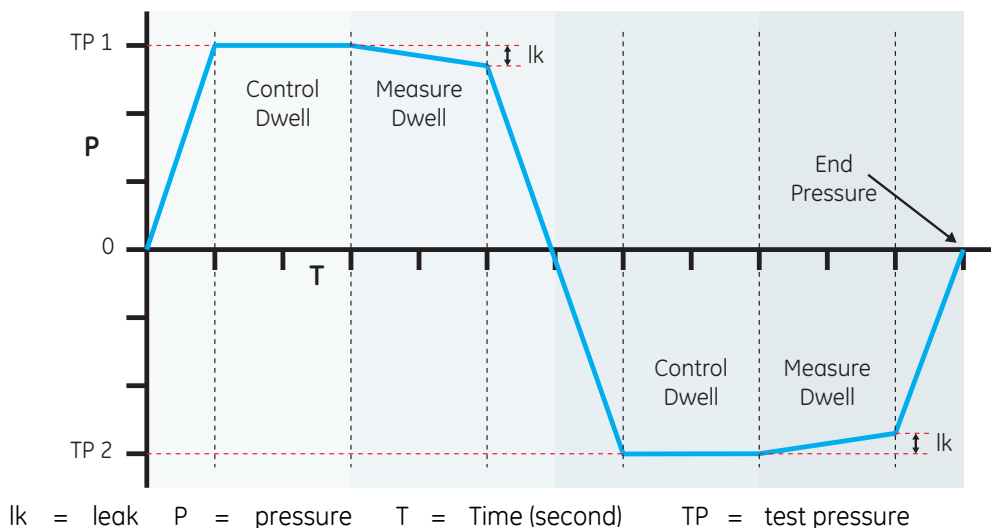

Switch Test Option

This function automates the testing of pressure switch devices. Connect the pressure port of the switch to be tested to the output port. Connect the switch contacts in series with the 24V dc output and the **Logic** Input.

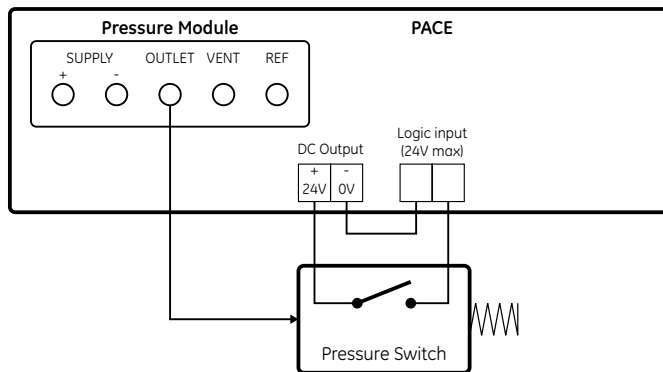
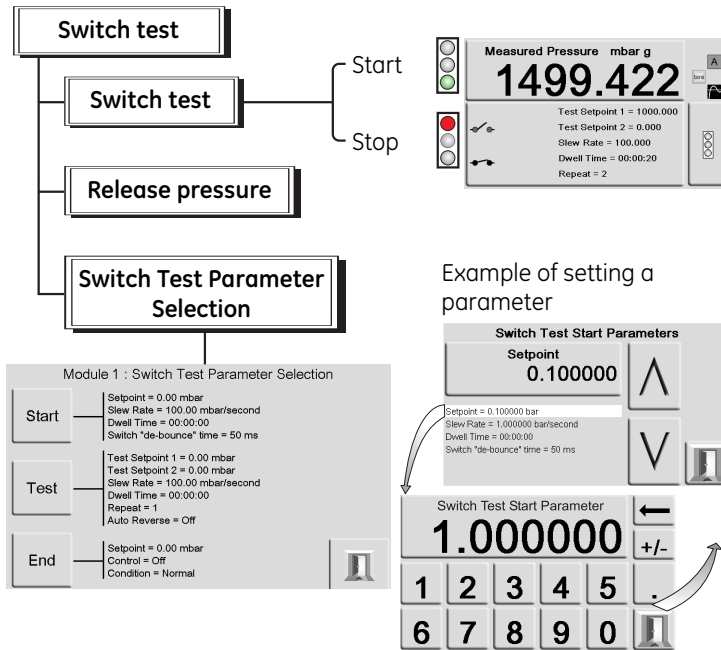

Figure 6-2 Example Switch Test Connections

Note: The volt-free logic input connections require a switching potential (24V max) to be applied. If necessary, this can be an external d.c. source. Common mode must be kept within 30V maximum.

Start

Controls pressure at a fast slew rate to a set-point just below expected switch operating point. De-bounce time can be increased for slower test slew rates.

Test

Controls pressure between two set-points and can repeat (loop). Auto-reverse can be selected.

End

Controls pressure to a safe condition to disconnect switch under test.

Procedure

Select the switch test parameters in the switch test menu, including the start pressure, end pressure and test rate of change. Slower rates give more accurate results. The de-bounce time can be set between 0 and 200 ms.

After the test, the display shows the pressures at which the contacts open and close and the switch hysteresis (the difference between the two switching pressures).

Before disconnecting the switch under test, press **Release pressure** to release any residual pressure.

Note: This switch test procedure can be repeated to “exercise” the switch unit.

Logic input is opto-isolated. An external supply (5V to 24V dc) can be used provided its' common mode voltage remains with 30V max with respect to chassis.



Test Program Option

The test program task provides a facility for writing and executing test procedures. Selecting a test program from the Task menu displays all the task programs currently stored, together with the ability to write new ones.

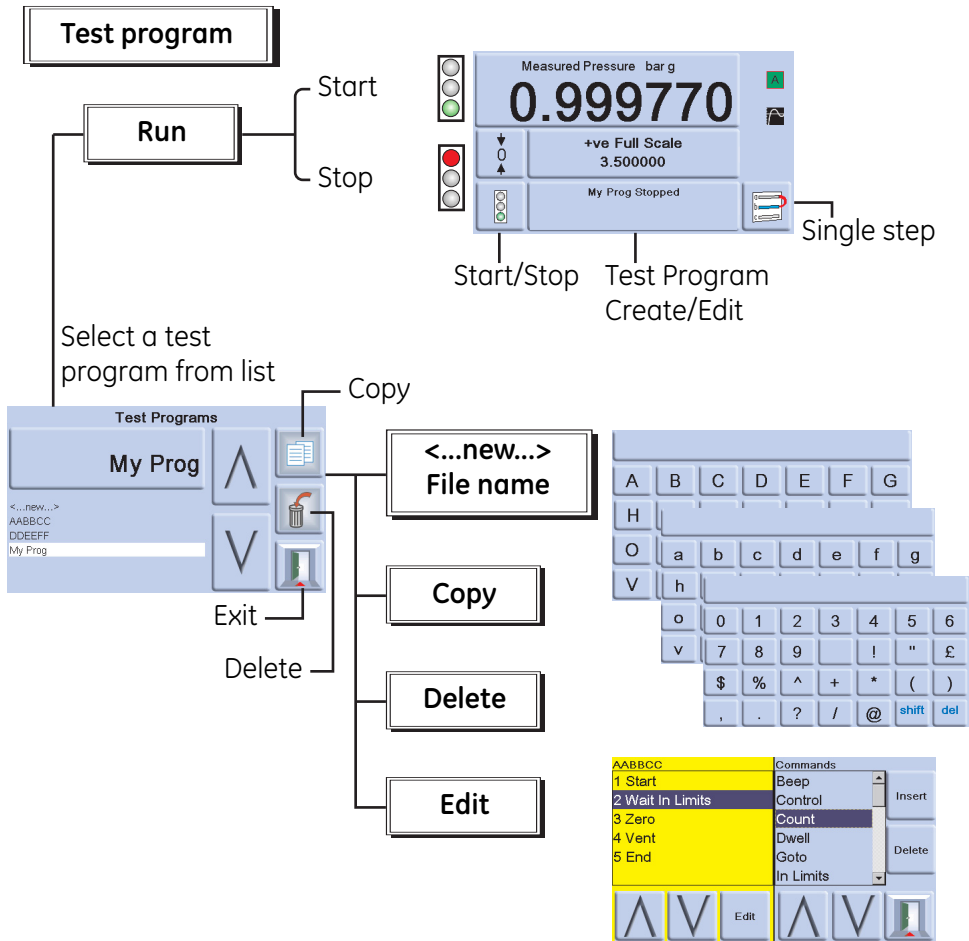

Creating a test program

1. Select the Test Program Create/Edit key.
2. Select New.
3. To enter a name for the program do the following:
 - a. Use the text editor keys to create the Test program name.
 - b. Press enter on completion.

Note: A new test always contains a START and END command (first and last line instructions), these lines cannot be deleted.

Editing an existing test program

1. Select the Test Program Create/Edit key.
2. Select the test program by name.
3. The display shows the test program to the left and available commands, that can be inserted, to the right.
4. To delete a command within a test program, select the command using the up/down arrow keys and then press the delete key.
5. To edit a command parameter within a test program, select the command using the up/down arrow keys and then press edit.
6. To save a created or edited test program, select the exit key, then select "Yes" to save and exit. "No" will exit the test program without saving any changes. "Cancel" will return you to the test program edit screen.

Running a test program

1. Select the Test Program Create/Edit key.
2. Select the test program listed on the screen then press Exit.
3. To start a test program, press Start.
4. When the program starts, a stop legend replaces the run legend.
5. Press the stop key at any time to stop the test program.

Copying a test program

This function allows you to make a copy of an existing Test program file to this instrument and rename it, copy files to a USB memory device and copy files from a USB memory device.

1. Press the Copy function button. Three options become available.
2. Select the desired option and follow the on-screen prompts.

Reference and Specification

Command	Description
Beep	Sounds a beep (on/off).
Break	Breaks to this point when stop count command or STOP icon is selected, then executes the code from the break statement to the end statement.
Control	Selects Control mode.
Count 1	Counter 1 - Used in a loop to count the number of loop cycles. (Legacy count).
Count 2	Counter 2 - Used in a loop to count the number of loop cycles.
Dwell	Specifies dwell time (seconds) within the test program.
GOTO	Used to set-up a loop. Enter program line number to go to.
If	If statement allows for a decision. For instance, if count 1 = 5 then GOTO xx
In Limits	In Limits band setting (% full-scale).
In Limits Timer	Waits, within In Limits for this time period, before setting a valid In Limits condition and continuing the Test program sequence.
I/P Logic	Specifies change of state for external contacts as a halt condition.
Isolation Valve	Control of output isolation valve: Isolated (closed) or Non-isolated (open).
Measure	Selects Measure mode.
Pause	Causes test program to pause and wait for user input (Resume).
Range	Specifies instrument range. Test program can only run within one control module.
Rate Max	Sets controller rate to maximum.
Rate Value	Specifies controller linear rate entered., per minute or second
Resolution	Sets display resolution.
Set Count 1	Sets the counter 1 internal value.
Set Count 2	Sets the counter 2 internal value.
Setpoint	Allows set-point to be entered.
Settling Fast	Used to specify controller fastest response, may overshoot.
Settling No Over-shoot	Used to specify controller response without overshoot.
Stop Count	Used to stop loop program after a number of loops. (Legacy support only, not recommended for use if count 1 and count 2 are listed).
Text	Sets screen message.
Units	Selects required display units.
Vent	Instructs the module to vent.
VFC Off	Sets VFC allocation test program off. (Legacy support only, not recommended for use if select VFC relay command is present).
VFC On	Sets VFC allocation test program on. (Legacy support only, not recommended for use if select VFC relay command is present).
Select VFC Relay	Allows control of VFC 1: R1 Allows control of VFC 2: R2 R3 When VFC is set to Test program under VFC setup.
Wait In Limits	Waits until pressure is within the limits.
Zero	Output zeroed

Table 6-3 Test Program Commands

When selected, certain commands require a value or selection to be set (e.g.) RANGE, RATE, TEXT the display shows a screen prompt for the appropriate setting.

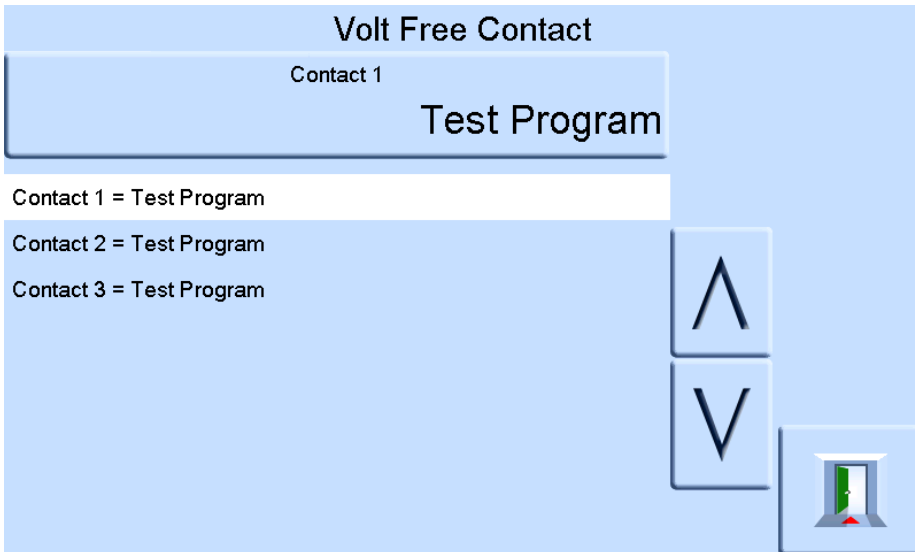
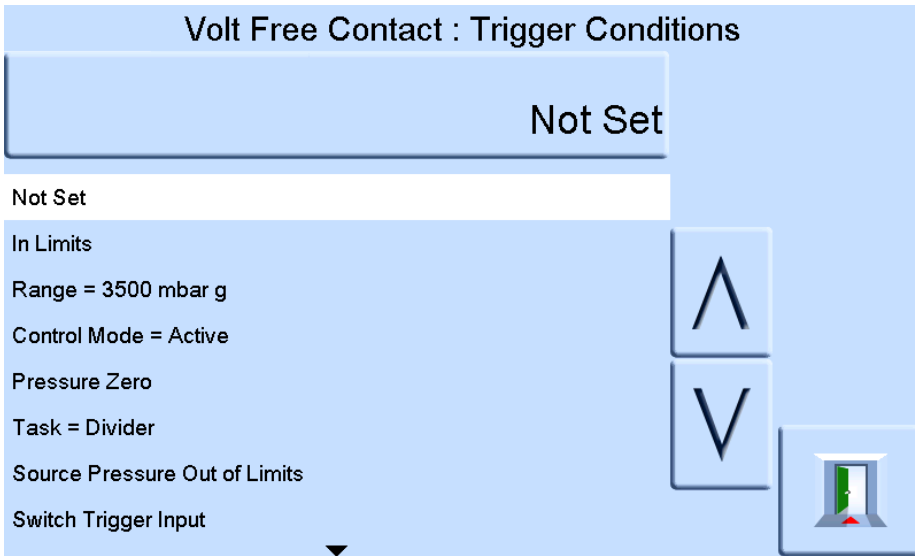

Reference and Specification

Example Program

Note: Changes to instrument settings made in a test program remain valid only for the test program.

The instrument reverts to the pre-test settings on exit to another task.

Step	Command	Argument	Action
1	START		Program start
2	UNITS	mbar	Select units, mbar
3	RATE	100	Select rate, 100 mbar/min
4	IN LIMITS TIME		10 (00:00:10) secs
5	IN LIMITS		Set In Limits Band
6	RESOLUTION	5	Display resolution, 5 digits
7	SETTLING		No overshoot
8	TEXT		Operator instruction, e.g. "Connect UUT"
9	ZERO		
10	SET POINT	400	Set-point, 400 mbar
11	CONTROL		Controller ON
12	WAIT IN LIMITS		Wait for In Limits Condition
13	BEEP		Beep on, approx. 1 sec, Beep off
14	MEASURE		Switch to Measure (controller off)
15	DWELL	30	<i>Wait for 30 sec (00:00:30)</i>
16	SET POINT	800	Set-point, 800 mbar
17	CONTROL		Controller on
18	WAIT IN LIMITS		Wait for In Limits Condition
19	BEEP ON		Beep on, approx. 1sec, Beep off
20	MEASURE		Switch to Measure (controller off)
21	TEXT		Operator instruction, e.g. <i>(Wait for beep, record pressure)</i>
22	DWELL	30	Wait for 30 sec
23	BEEP		Beep on, approx. 1 sec, Beep off
24	TEXT		Operator instruction, e.g. <i>"Min pressure allowed 785 mbar"</i>
25	PAUSE		<i>WAIT</i> , (for operator input to touch single step)
26	VENT		Vent
27	END		Program end

Programming Loops

To program a loop, use the GOTO command.

Include the COUNT command in the loop for counting the number of loop cycles.

Note: The test program commands do not include tests for conditional jumps.

To stop a test program from looping, STOP must be selected by the operator.

Example of programming a loop

Step	Command	Argument	Action
1	START		Program start
2	UNITS	mbar	Select units, mbar
3	RATE VALUE	100	Select rate 100mbar/min
4	RESOLUTION	5	Display resolution 5 digits
5	IN LIMITS		Sets the In-limits band
6	IN LIMITS TIME		10 (00:00:10) secs
7	SETTLING NO OVERSHOOT		No overshoot
8	TEXT		Operator instruction, e.g. "Connect UUT"
9	ZERO		Performs a sensor zero
10	SET POINT	400	Set-point, 400 mbar
11	CONTROL		Controller ON
12	WAIT IN LIMITS		Wait for In-limits condition
13	BEEP ON		Beep on, approx. 1sec, Beep off
14	MEASURE		Switch to measure (controller off)
15	DWELL	30	Wait, 30 sec
16	SET POINT	800	<i>Set-point, 800 mbar</i>
17	CONTROL		Controller on
18	WAIT IN LIMITS		Wait for In-limits condition
19	BEEP ON		Beep on, approx. 1sec, Beep off
20	MEASURE		Switch to measure, controller off
21	COUNT 1		Increment loop counter
22	VENT		Vent
23	GOTO	9	Loop back to program line 9
24	BREAK		
25	SET POINT	0	
26	WAIT IN LIMITS		
27	MEASURE		
28	END		Program end

Barometric Reference Option

The barometric reference option measures the barometric pressure at the reference port. When installed, this option allows absolute or gauge pressure range selection. To obtain absolute pressure the instrument uses a summation of gauge pressure and barometric pressure (measured by the barometric sensor).

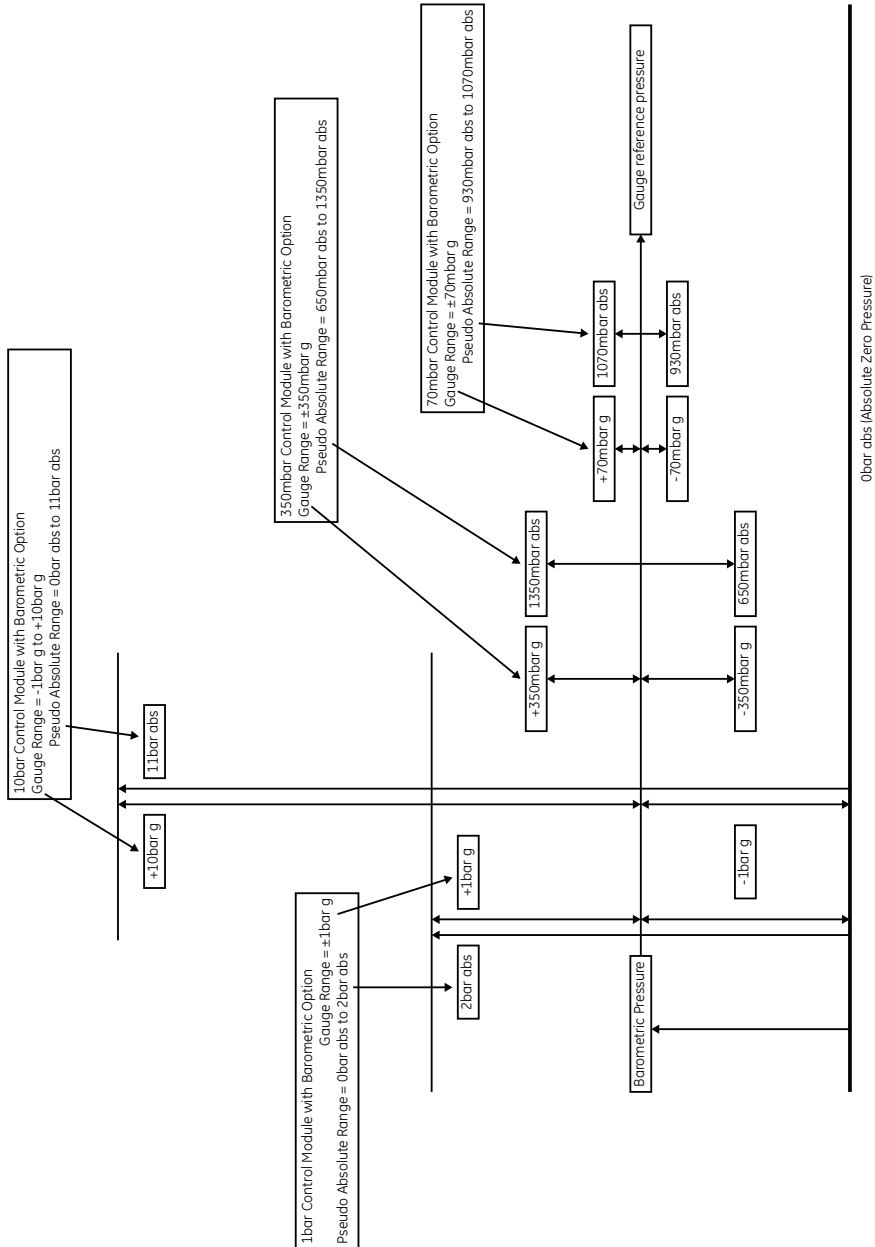

Ref: Data sheet 920-561 for the barometric reference and precision of absolute ranges.

Aeronautical Option

The aeronautical option is a specialised application of the PACE instrument.

Note: The PACE instrument must be set-up very carefully so that the aeronautical pressures applied do not exceed maximum pressure values and rates of change.

Leak testing



CAUTIONS

DO NOT EXCEED THE MAXIMUM PRESSURES STATED IN THE APPROPRIATE COMPONENT MAINTENANCE MANUAL FOR THE UNIT UNDER TEST.

CAREFULLY DE-PRESSURIZE ALL PIPES TO ATMOSPHERIC PRESSURE BEFORE DISCONNECTING AND CONNECTING TO THE UNIT UNDER TEST.

Before testing an aeronautical component do a leak test.

This task sets the test pressure, dwell time at the test pressure and the leak test time.

At the start of the test, the instrument applies a test pressure to the user system.

A dwell time allows the user system to stabilise.

Aeronautical testing

The aeronautical task enables control and measurement of the following:

- Altitude (feet/metres)
- Airspeed (knots, mph, km/h)

This task utilises dual pressure displays to show the parameter and the rate of change of the following:

- Altitude
- Airspeed
- Mach and Airspeed with Mach number

The aeronautical task enables the testing and calibration checking of aeronautical indicators and system components by controlling and displaying values and rates in aeronautical units.

When using a single instrument, the pressure supply must be changed when changing from Altitude to Airspeed.

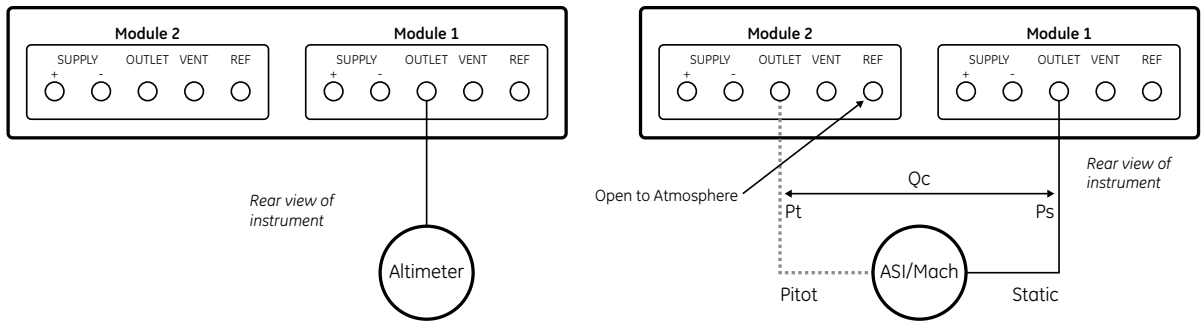

Example of Altitude and Airspeed Testing

This example shows how two-channel PACE instruments can be used to generate altitude and airspeed.



CAUTIONS

BEFORE TESTING, SET THE RATES OF CHANGE FOR BOTH PITOT AND STATIC TO A SAFE VALUE. A HIGH RATE OF CHANGE CAN DAMAGE SENSITIVE AERONAUTICAL COMPONENTS. REFER TO THE APPROPRIATE COMPONENT MAINTENANCE MANUAL FOR THE UNIT UNDER TEST.

IN THIS EXAMPLE CONFIGURATION, NEGATIVE AIRSPEED CAN BE GENERATED THIS CAN DAMAGE AN AIRSPEED INDICATOR. TO PREVENT NEGATIVE AIRSPEED, APPLY THE STATIC PRESSURE BEFORE THE PITOT PRESSURE FOR INCREASING AND DECREASING AIRSPEED VALUES.

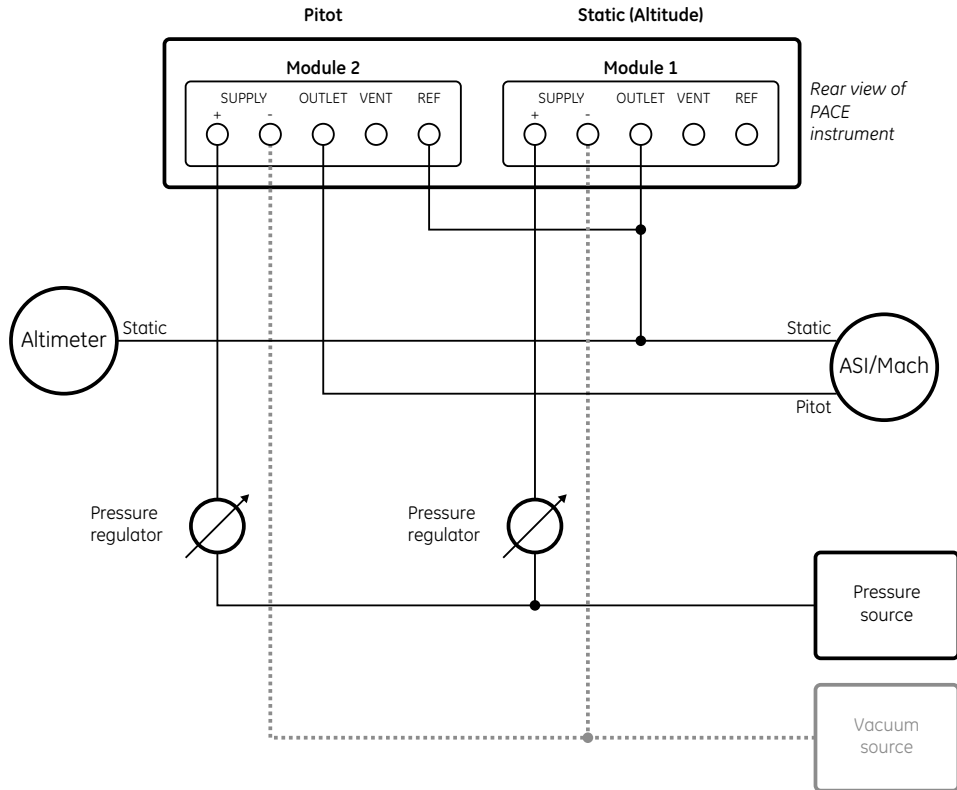

Units

The units can be either the aeronautical or pressure units. The units can be changed any time between pressure and pressure converted to aeronautical units. The display shows the output pressure converted to Altitude, CAS or Mach using BS 2G 199:1984* conversions and assuming standard atmospheric conditions.

* Based on tables from ICAO Standard Atmosphere 1964.

Reference Pressure

Select the required reference pressure, this can be either the barometric pressure (from the instrument's internal barometric sensor), or any numeric value (e.g.) 1013.25 mbar.

Go to ground

Returns the instrument and any UUT, connected to it, safely to ground pressure at a controlled rate.

Control of Aeronautical parameters

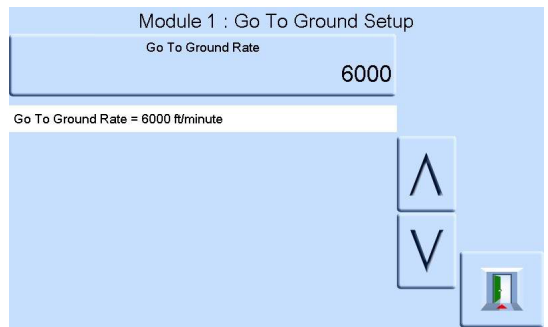
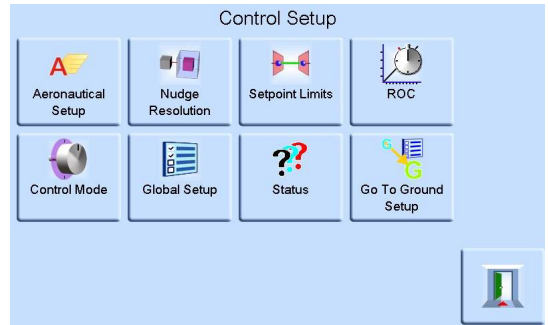
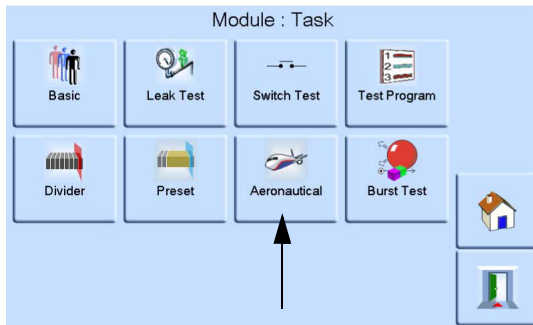

The aeronautical control is an intergrated controller. The two modules work together as a dual channel pressure controller (Ref: [Figure 6-3](#)).

In aeronautical mode, the display goes to the last selected parameter:

- Altitude
- Airspeed
- Mach

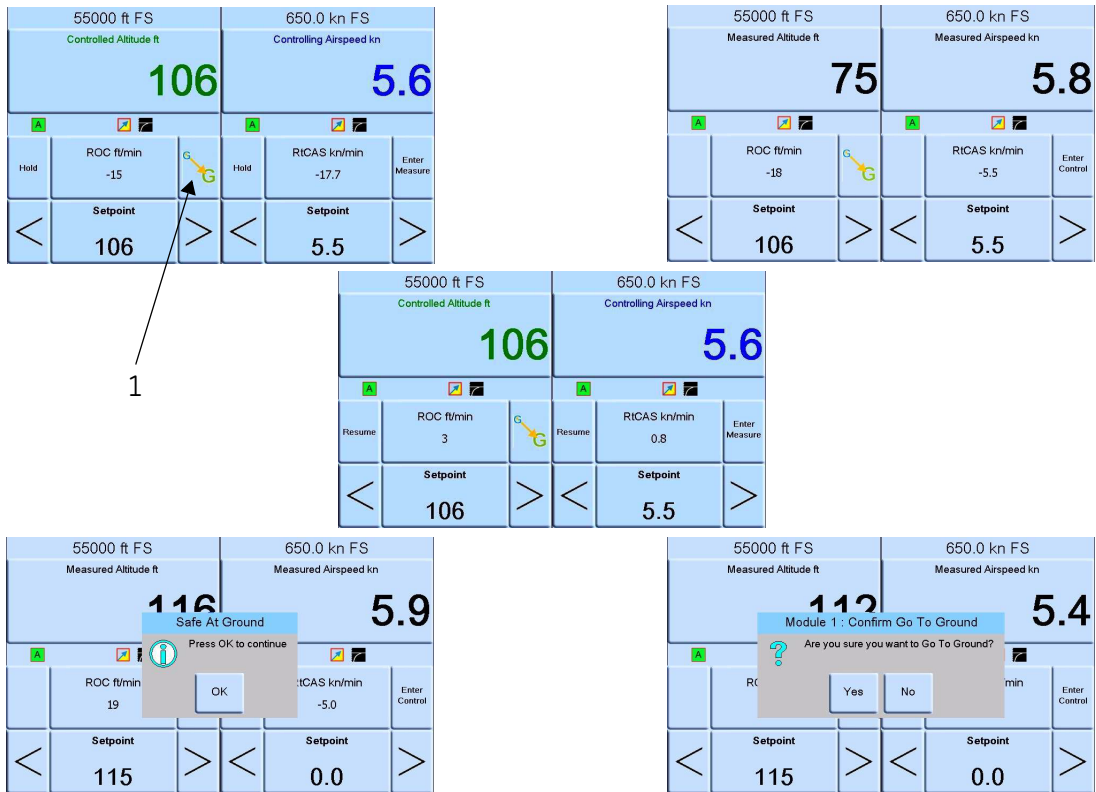

Figure 6-3 Screen layout

In dual screen mode both altitude and airspeed controllers are set to control mode, by selecting the Enter Control key (Ref: Figure 6-3).

The Enter Measure key sets both controllers to measure mode.

Select 1 (Go to Ground) in (Ref: Figure 6-3) to make both controllers go to ground.

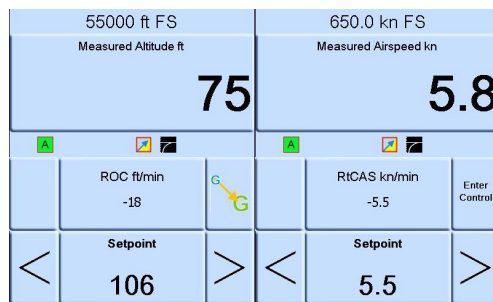

Figure 6-4 Measurement mode

(Ref: Figure 6-4) both controllers in measurement mode.

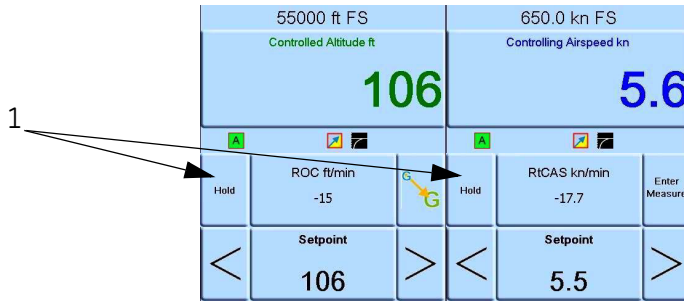

Figure 6-5 Control mode

(Ref: Figure 6-5) both controllers in control mode.

In control mode each control can have an individual set-point.

Select 1 (Hold) in (Ref: Figure 6-5) to hold a set altitude or speed.

Note: The altitude and airspeed controllers are still actively ON, but held at the selected range.

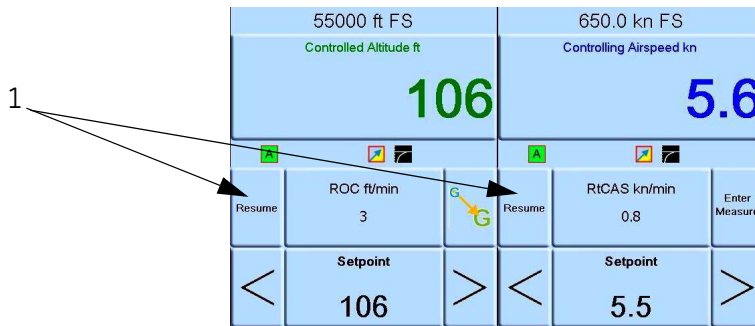

Figure 6-6 Set-points

Select 1 (Resume) in (Ref: Figure 6-6) to continue to the altitude and speed set-points.

Analogue Output Option

The analogue output option provides a selectable output of voltage or current.

Analogue O/P Setup

0 to 10V

Selects Analogue Output Range

- 0 to 10V (Off)
- 0 to 5V
- 5 to +5V
- 4 to 20mA
- 0 to 20mA

Analogue Output : 4 to 20mA

Condition Off

On/Off

Condition = Off

4mA = 0.0 mbar

20mA = 0.0 mbar

Update Rate = 10 readings/sec

Analogue Output : 4 to 20mA

Update Rate 10

Update Rate

Condition = Off

4mA = 0.0 mbar

20mA = 0.0 mbar

Update Rate = 10 readings/sec

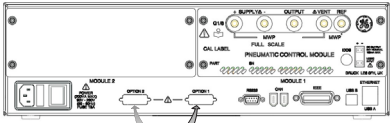

analogue connections

30V_{max}

30V maximum with respect to chassis.
Rated output = 24V

To maintain PACE product safety, external circuits connected to the instrument must meet Safety Extra-Low Voltage (SELV) requirements.

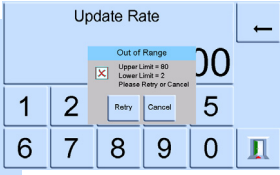

15-way female D connector

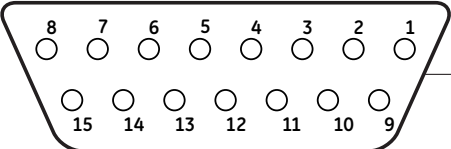

Front view of Analogue Option PCB connector

30V_{max}

Analogue Output Bandwidth = 0.5 x Update Rate (Hz)

Pin number	Function	Pin number	Function
1	not used	9	not used
2	not used	10	0V return
3	not used	11	+24V DC OUT @ 100mA
4	not used	12	SW IN 1
5	not used	13	SW IN 2
6	not used	14	analogue +
7	not used	15	analogue -
8	not used		

Reference and Specification

Volts-free Contact Option

The Volts-free Contact option provides a selectable output of voltage or current.

Each selection has three Volts-free Contacts.

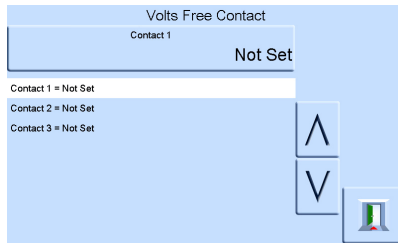

Selection of trigger conditions.

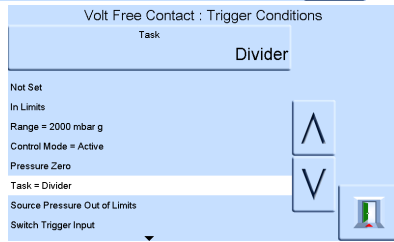

Selection of trigger conditions.

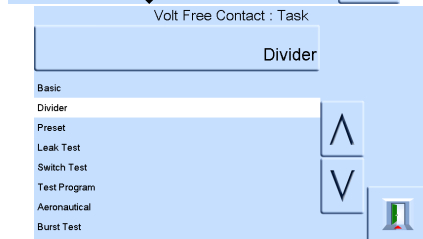

Relay contacts rated at 30 Vdc, 1 A resistive, 200 mA inductive.

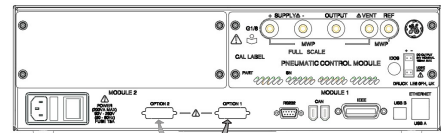

volts-free connections



30V maximum with respect to chassis.

Rated output = 24V

To maintain PACE product safety, external circuits connected to the instrument must meet Safety Extra-Low Voltage (SELV) requirements.

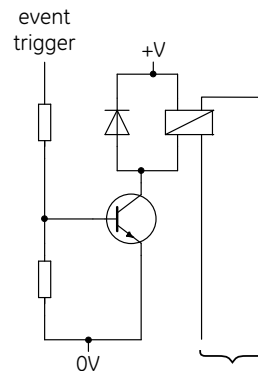

Typical Volts-free schematic

24 Vdc maximum
30 Vdc wrt chassis
1 A resistive maximum

Pin number	Function	Pin number	Function
1	Relay 1 normally CLOSED	9	Relay 3 common
2	Relay 1 normally OPEN	10	0V return
3	Relay 1 common	11	+24V DC OUT @ 100mA
4	Relay 2 normally CLOSED	12	SW IN 1
5	Relay 2 normally OPEN	13	SW IN 2
6	Relay 2 common	14	not used
7	Relay 3 normally CLOSED	15	not used
8	Relay 3 normally OPEN		

6.9 Calibration

The calibration menu provides facilities for programming settings for maintenance as follows:

Note: A PIN protects the Calibration menu against unauthorised use. Each instrument, on delivery, contains the factory set PIN (4321). To continue protecting the supervisor set-up menu, the PIN should be changed as soon as possible.

+ve source zero	
-ve source zero	
sensor correction	Selects the range for a three-point calibration routine.
valve correction	
source PDCR correction	three-point calibration of both source pressure sensors
screen calibration	
Time & Date	Sets instrument clock and calendar.
Change PIN	Changes the Calibration PIN. Enter the existing PIN, the new PIN and confirmation of the new PIN. <i>Should this new PIN become lost it can only be reset by returning the instrument to a GE service centre.</i>

6.10 Communications - Instrument Emulation

(Ref: K0469 - PACE Communications Manual - Instrument Emulation).

6.11 Specification

(Ref: PACE Module Pressure Controller data sheet).

Note: Data sheet 920-561 is contained in the CD shipped with the product.

6.12 Return Goods/Material Procedure

If the unit requires calibration or is unserviceable return it to the nearest GE Service Centre listed at www.gemeasurement.com.

Contact the Service Department, by 'phone, fax or E-mail to obtain a Return Goods Authorisation (RGA) (Worldwide excluding USA).

In the USA obtain a Return Material Authorization [RMA].

- Product (i.e. PACE5000)
- Serial number
- Details of defect/work to be undertaken
- Calibration traceability requirements
- Operating conditions

Safety Precautions

You must inform GE if the product has been in contact with any hazardous or toxic substance.

The relevant COSHH or in the USA, MSDS, references and precautions to be taken when handling.

Important Notice

Service or calibration by unauthorized sources will affect the warranty and may not guarantee further performance.

6.13 Packaging Procedure

1. The instrument should be at zero/ambient pressure.
2. Switch off and isolate the electrical power supply to the instrument.
3. Shut off the pneumatic pressure and vacuum supplies to the instrument.
4. Remove the instrument from the equipment rack to access the rear panel.
5. Disconnect the power supply cable and the pneumatic supply hose assemblies.
6. Stow the power supply cable in the packaging below.
7. Remove any pressure adaptors, diffusers and restrictors.

If available, use the original packing material. When using packing materials other than the original, do the following:

8. Fit protection to all the ports to prevent ingress of moisture and dirt.

Note: Use the original red plastic plugs or low tack masking tape.

9. Wrap unit in polyethylene sheeting.
10. Select a double-wall cardboard container.
 - Inside dimensions must be at least 15 cm (6") greater than the equipment
 - The carton must meet test strength requirements of ≥ 125 kg (275 lbs).
11. Protect all sides with shock-absorbing material to prevent equipment movement within the container.
12. Seal carton with approved sealing tape.
13. Mark carton "FRAGILE" on all sides, top, and bottom of shipping container.

Environment

The following conditions apply for both shipping and storage:

- Temperature range: -20° to $+70^{\circ}\text{C}$ (-4° to $+158^{\circ}\text{F}$)

6.14 Vacuum System Parts

The parts list below lists a typical system to supply vacuum, enabling the control of sub-atmospheric pressures by the PACE instrument. Part numbers quoted in the table are taken from the BOC Edwards Vacuum Products Catalogue. For more information, go to:

www.bocedwards.com.

Description	Part Number	Quantity
RV5 115/230Vac Vacuum Pump, 91 litre/min	A653-01-903	1
EMF10 Mist Filter	A462-26-000	1
NW25/NW10 Reducer fitting	C105-14-436	2
NW10 T-Piece Fitting	C105-11-411	1
IPVA10EK Air Admittance Valve, Normally Open	C417-21-000	1
NW10 Flexible Pipeline 1m, S/S	C105-11-287	4
NW10 Clamping Ring	C105-12-401	5
NW10 Centering Ring	C105-11-398	5
NW25 Clamping Ring	C105-14-401	3
NW25 Centering Ring	C105-14-398	3
NW16/10 Centering Ring	C105-12-349	1
NW16 to ¼NPT Male Adapter, S/S	C105-01-103	1
FL20K Foreline Trap	FL-20-K	1

Intentionally Blank

